

Kupsch Diamantwerkzeuge GmbH

Inhaltsverzeichnis

Preisliste

Diamanttrennscheiben	Seite
Fugenschneider Beton, Stahlbeton, Asphalt, Frischbeton	2-3
Wandsäge /Kurz Zahn / Laser (Beton, Stahlbeton, Naturstein, Mauerwerk)	3-4
Tischsäge Beton (Beton, allgemeine Baumaterialien)	5
Tischsäge Abrasiv (Kalksandstein, Poroton, Bims, weicher Klinker)	6
Tischsäge Feuerfestmaterial (Schamotte, Ofenkacheln, Korund)	7-8
Trockenschnitt (Granit, Beton, Asphalt, Keramik, Fliesen, Feinsteinzeug, Estrich, etc.)	9-14
Granit	15-18
Blocksäge (Granit, Sandstein)	19
Marmor	20
Sandstein	21

Diamantbohrkronen	Seite
Stahlbeton	22
Granit	23
Marmor / Fliesen	24
Asphalt / Abrasiv	25
Mauerwerk	26
Bohrkronen mit Ringsegment (Stahlbeton, Granit, abrasive Materialien)	27
Dosensenker „Laser“ - Trockenbohrkronen „Laser“ (Softschlag)	28-29
Fliesenbohrkronen	30
Vollbohrer - Diamantbohrkronen Rohlinge	31

Schleif- und Fräswerkzeuge	Seite
Schleifteller, Topfschleifer, PKD	32-33
Polierpads	34
Rillenfräser Asphalt, Beton, Granit	35-37
Umfangfräser, Fugenfräser, V-Fräser, Fasenfräser	38
Bodenschleifplatten, Schleifleisten, Schleifschuhe, PKD	39-40

Segmente	Seite
Bohrkronen Segmente (Granit)	41
Bohrkronen Segmente (Marmor)	42
Bohrkronen Segmente (Stahlbeton, Asphalt)	43-45
Ringsegmente (Beton, Stahlbeton, Granit, abrasive Materialien)	46

Sonstiges	Seite
Abzug Wiederbelag	47
Adapter und Verlängerungen	48
Zubehör	49

Diamanttrennscheiben ⇒ Nassschnitt (wet cut) Fugenschneider - joint cutter

Fugenschneider ⇒ Beton

Beton, Stahlbeton • concrete, reinforced concrete

∅	Art.-Nr.	Segment Anzahl	Segment Breite	Belaghöhe 7+1 mm	Belaghöhe 10 mm
300	10101	18	2,8	114,30 €	-
350	10102	21	3,2	138,30 €	-
400	10103	24	3,8	165,40 €	187,50 €
450	10104	26	3,8	196,00 €	221,80 €
500	10105	30	3,8	222,30 €	250,10 €
550	10106	32	4,6	259,10 €	300,20 €
600	10107	36	3,8 Reduziert	272,70 €	308,50 €
600	10108	36	4,6	290,30 €	336,50 €
650	10109	38	4,6	342,80 €	394,90 €
700	10110	40	4,6	348,80 €	402,10 €
750	10111	44	4,6	407,90 €	469,50 €
800	10112	46	4,6	418,50 €	480,90 €
850	10113	48	4,6	465,90 €	531,70 €
900	10114	50	4,6	476,90 €	544,90 €
1000	10115	50	4,6	551,10 €	625,80 €
1200	10116	54	4,6	839,40 €	911,40 €
1300	10117	66	4,6	1.236,20 €	1.343,70 €
1400	10118	70	4,6	1.330,10 €	1.445,60 €
1500	10119	76	4,6	1.477,60 €	1.641,40 €
1600	10120	78	4,6	1.977,30 €	2.182,20 €
1800	10121	92	4,6	3.164,10 €	3.466,90 €
2000	10122	100	4,6	3.399,30 €	3.724,20 €

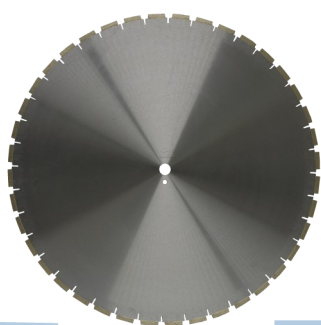

Fugenschneider ⇒ Asphalt

Asphalt, abrasive Materialien • asphalt, abrasive materials

∅	Art.-Nr.	Segment Anzahl	Segment Breite	Schrägsegment 7+1 mm	Hammersegment 7+1 mm
300	10201	18	2,8	118,40 €	136,60 €
350	10202	21	3,2	145,60 €	166,80 €
400	10203	24	3,8	176,40 €	207,00 €
450	10204	26	3,8	207,50 €	233,90 €
500	10205	30	3,8	234,80 €	265,20 €
550	10206	32	4,6	288,80 €	321,20 €
600	10207	36	3,8 Reduziert	298,70 €	335,20 €
600	10208	36	4,6	325,00 €	361,50 €
650	10209	38	4,6	376,40 €	415,90 €
700	10210	40	4,6	383,70 €	435,50 €
750	10211	44	4,6	447,00 €	515,90 €
800	10212	46	4,6	456,10 €	525,00 €
850	10213	48	4,6	496,70 €	565,60 €
900	10214	50	4,6	510,40 €	582,30 €
1000	10215	50	4,6	578,20 €	653,10 €
1200	10216	54	4,6	822,20 €	912,10 €
1300	10217	66	4,6	1.254,10 €	1.353,00 €
1400	10218	70	4,6	1.347,70 €	1.452,50 €
1500	10219	76	4,6	1.494,10 €	1.607,90 €



Diamanttrennscheiben ⇒ Nassschnitt (wet cut) Fugenschneider/Wandsäge - joint cutter/wall saw

Fugenschneider ⇒ Frischbeton

Frischbeton, Estrich, abrasive Materialien •

fresh concrete, green concrete, abrasive materials

Ø	Art.-Nr.	Segment Anzahl	Segment Breite	Belaghöhe 9+1 mm
300	103011	18	2,8	162,70 €
350	103021	21	3,2	200,80 €
400	103031	24	3,8	246,50 €
450	103041	26	3,8	287,10 €
500	103051	30	3,8	327,30 €
550	103061	32	4,6	398,80 €
600	103071	36	3,8 Reduziert	446,70 €
600	103081	36	4,6	459,00 €
650	103091	38	4,6	515,00 €
700	103101	40	4,6	562,70 €
750	103111	44	4,6	580,20 €
800	103121	46	4,6	617,70 €
850	103131	48	4,6	660,40 €
900	103141	50	4,6	681,90 €
1000	103151	50	4,6	760,80 €
1200	103161	54	4,6	1.052,00 €
1300	103171	66	4,6	1.536,00 €
1400	103181	70	4,6	1.648,10 €
1500	103191	76	4,6	1.822,80 €
1600	103201	78	4,6	2.340,70 €
1800	103211	92	4,6	3.572,90 €
2000	103221	100	4,6	3.835,40 €

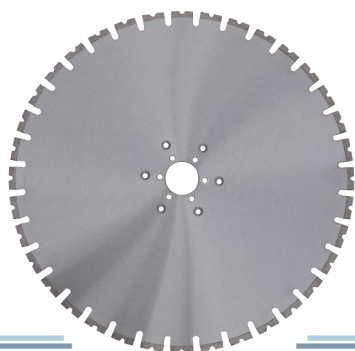
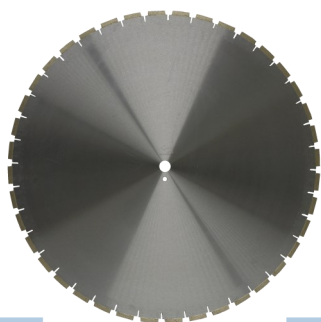

Wandsäge Laser ⇒ Beton Type: K-WSL

Beton, Stahlbeton, Naturstein, Mauerwerk •

concrete, reinforced concrete, masonry

Ø	Art.-Nr.	Segment Anzahl	Segment Breite	Belaghöhe 10 mm
600	601001	36	5,0	248,00 €
800	601002	46	4,7	387,20 €
1000	601003	56	4,5	651,50 €

Diamanttrennscheiben ⇒ Nassschnitt (wet cut) Wandsäge - wall saw

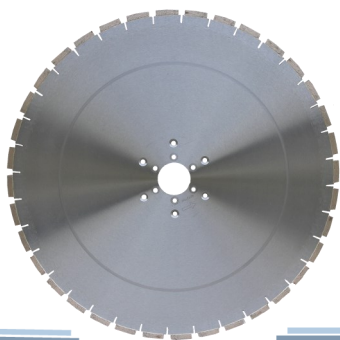

Wandsäge ⇒ Beton

Beton, Stahlbeton, Mauerwerk •
concrete, reinforced concrete, masonry

Ø	Art.-Nr.	Segment Anzahl	Segment Breite	Belaghöhe 10 mm
400	104001	24	3,8	183,70 €
450	104002	26	3,8	217,40 €
500	104003	30	3,8	245,00 €
550	104004	32	4,6	299,60 €
600	104005	36	3,8 Reduziert	315,20 €
600	104006	36	4,6	335,80 €
650	104007	38	4,6	394,10 €
700	104008	40	4,6	401,30 €
750	104009	44	4,6	468,60 €
800	104010	46	4,6	480,00 €
850	104011	48	4,6	530,80 €
900	104012	50	4,6	543,90 €
1000	104013	50	4,6	624,80 €
1200	104014	54	4,6	910,20 €
1300	104015	66	4,6	1.281,30 €
1400	104016	70	4,6	1.378,00 €
1500	104017	76	4,6	1.596,20 €
1600	104018	78	4,6	1.940,50 €
1800	104019	92	4,6	3.050,40 €
2000	104020	100	4,6	3.167,00 €

Wandsäge ⇒ Beton (Kurzzahntechnik)

Beton, Stahlbeton, Mauerwerk •
concrete, reinforced concrete, masonry

Ø	Art.-Nr.	Segment Anzahl	Segment Breite	Belaghöhe 10 mm
400	105001	48	3,8	219,90 €
450	105002	52	3,8	257,20 €
500	105003	60	3,8	290,80 €
550	105004	64	4,6	338,00 €
600	105005	72	3,8 Reduziert	357,70 €
600	105006	72	4,6	379,00 €
650	105007	76	4,6	441,90 €
700	105008	80	4,6	450,20 €
750	105009	88	4,6	525,20 €
800	105010	92	4,6	536,90 €
850	105011	96	4,6	589,40 €
900	105012	100	4,6	604,80 €
1000	105013	100	4,6	690,10 €
1200	105014	108	4,6	993,90 €
1300	105015	132	4,6	1.395,50 €
1400	105016	140	4,6	1.500,50 €
1500	105017	154	4,6	1.719,00 €
1600	105018	156	4,6	2.134,90 €
1800	105019	184	4,6	3.269,10 €
2000	105020	200	4,6	3.373,40 €

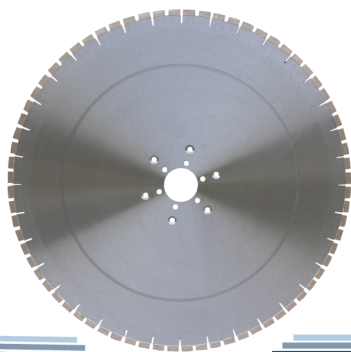

Diamanttrennscheiben ⇒ Nassschnitt (wet cut) Tischsäge Beton - table saw concrete

Beton ⇒ Normalkern (Normal verzahnt)

Beton, allgem. Baumaterialien (nicht für abrasives Material) •
concrete, general building materials (not for abrasive materials)

∅	Art.-Nr.	Segment Anzahl	Segment Breite	Belaghöhe 7+1 mm	Belaghöhe 9+1 mm
250	10601	15	2,8	88,90 €	101,40 €
300	10602	18	2,8	105,10 €	116,20 €
350	10603	21	2,8	127,20 €	140,60 €
400	10604	24	3,6	152,00 €	167,90 €
450	10605	26	3,8	179,90 €	197,50 €
500	10606	30	3,8	207,20 €	227,50 €
550	10607	32	4,6	238,80 €	262,10 €
600	10608	36	4,6	266,70 €	292,90 €
625	10609	36	4,6	278,40 €	304,60 €
650	10610	38	4,6	310,60 €	339,00 €
700	10611	40	4,6	322,40 €	351,50 €
750	10612	44	4,6	375,60 €	409,10 €
800	10613	46	4,6	384,40 €	417,90 €
850	10614	48	4,6	438,20 €	473,60 €
900	10615	46	4,6	439,10 €	474,00 €
1000	10616	50	4,6	506,90 €	543,30 €
1100	10617	54	4,6	635,90 €	675,30 €
1200	10618	54	4,6	745,10 €	788,80 €

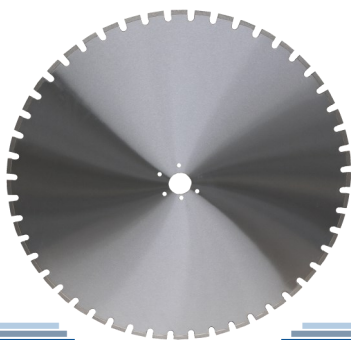

Beton ⇒ Leisekern (Normal verzahnt)

Beton, allgem. Baumaterialien (nicht für abrasives Material) •
concrete, general building materials (not for abrasive materials)

∅	Art.-Nr.	Segment Anzahl	Segment Breite	Belaghöhe 7+1 mm	Belaghöhe 9+1 mm
300	10702	18	2,8	142,70 €	157,70 €
350	10703	21	3,2	181,50 €	199,50 €
400	10704	24	3,6	203,30 €	224,50 €
450	10705	26	3,8	242,40 €	265,70 €
500	10706	30	3,8	270,80 €	297,70 €
550	10707	32	4,6	340,20 €	370,50 €
600	10708	36	4,6	409,40 €	443,50 €
625	10709	36	4,6	420,30 €	454,40 €
650	10710	38	5,0	483,80 €	519,80 €
700	10711	40	5,0	512,10 €	550,00 €
750	10712	44	5,5	582,00 €	623,60 €
800	10713	46	5,5	649,80 €	693,40 €
900	10714	52	6,0	876,50 €	907,30 €

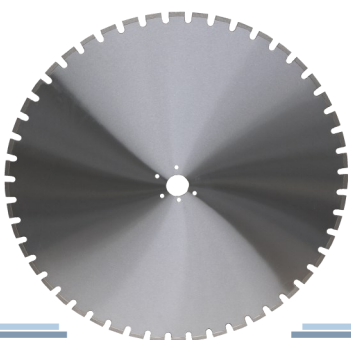

Diamanttrennscheiben ⇒ Nassschnitt (wet cut) Tischsäge Abrasiv - table saw abrasive

Abrasiv ⇒ Normalkern (Normal verzahnt)

Kalksandstein, Poroton, Bimsstein, weiche Klinker, abrasives Material •
sand-lime brick, poroton, pumice, red bricks, abrasive materials

∅	Art.-Nr.	Segment Anzahl	Segment Breite	Belaghöhe 7+1 mm	Belaghöhe 9+1 mm
250	10801	15	2,8	87,50 €	98,80 €
300	10802	18	2,8	92,70 €	109,10 €
350	10803	21	2,8	116,30 €	126,70 €
400	10804	24	3,6	152,40 €	166,90 €
450	10805	26	3,8	184,30 €	199,80 €
500	10806	30	3,8	216,30 €	233,80 €
550	10807	32	4,6	226,60 €	273,90 €
600	10808	36	4,6	242,00 €	317,20 €
625	10809	36	4,6	260,50 €	335,80 €
650	10810	39	4,6	291,40 €	371,80 €
700	10811	40	4,6	311,00 €	392,40 €
750	10812	44	4,6	356,30 €	453,20 €
800	10813	46	4,6	367,70 €	463,50 €
850	10814	48	4,6	404,70 €	508,80 €
900	10815	46	4,6	405,70 €	510,50 €
1000	10816	54	4,6	578,80 €	669,40 €
1200	10817	54	4,6	729,10 €	792,50 €

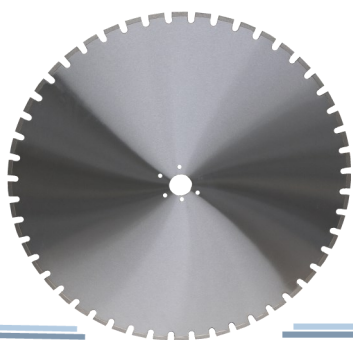

Abrasiv ⇒ Uni-Line

Type: K-BSU

Kalksandstein, Poroton, Bimsstein, weiche Klinker, abrasives Material •
sand-lime brick, poroton, pumice, red bricks, abrasive materials

∅	Art.-Nr.	Segment Anzahl	Segment Breite mm	Bohrung mm	Belaghöhe 10 mm
625	640001	38	4,4	60	222,50 €
650	640002	40	4,4	60	243,00 €
700	640003	43	4,4	60	278,00 €
750	640004	45	4,5	60	287,50 €
800	640005	48	4,8	60	295,00 €
900	640006	48	4,8	60	299,00 €
900	640007	52	4,8	60	329,50 €

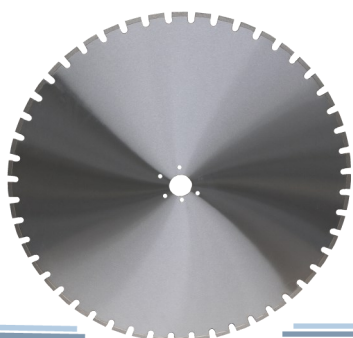

Abrasive ⇒ Leisekern (Normal verzahnt)

Kalksandstein, Poroton, Bimsstein, weiche Klinker, abrasives Material •
sand-lime brick, poroton, pumice, red bricks, abrasive materials

∅	Art.-Nr.	Segment Anzahl	Segment Breite	Belaghöhe 7+1 mm	Belaghöhe 9+1 mm
300	10902	18	2,8	136,70 €	145,80 €
350	10903	21	2,8	172,70 €	183,30 €
400	10904	24	3,6	192,10 €	205,30 €
450	10905	26	3,8	229,80 €	243,50 €
500	10906	30	3,8	256,20 €	272,00 €
550	10907	32	4,6	321,10 €	338,60 €
600	10908	36	4,6	387,90 €	407,60 €
650	10909	39	5,0	484,70 €	508,70 €
700	10910	40	5,0	507,60 €	532,10 €
750	10911	44	5,5	589,60 €	620,80 €
800	10912	46	5,5	646,60 €	677,90 €
900	10913	52	6,0	873,10 €	922,10 €

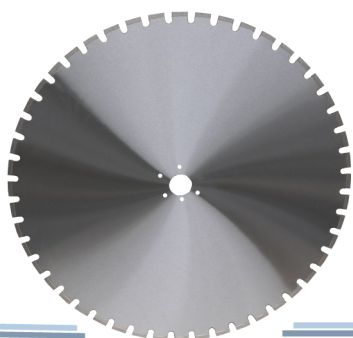

Diamanttrennscheiben ⇒ Nassschnitt (wet cut) Tischsäge Feuerfest - table saw refractory

Feuerfest ⇒ Normalkern (Normal verzahnt)

Schamotte, Feuerfest Materialien, Korund •
fire clay, refractory materials, corundum

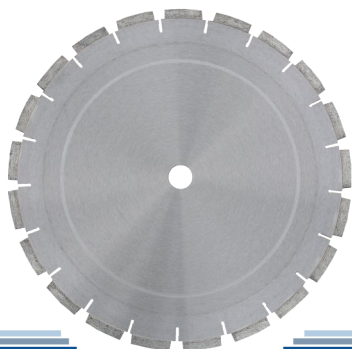

Ø	Art.-Nr.	Segment Anzahl	Segment Breite	Belaghöhe 6+1 mm	Belaghöhe 9+1 mm
300	11001	18	2,8	151,50 €	171,60 €
350	11002	21	2,8	183,50 €	210,30 €
400	11003	24	3,6	222,40 €	256,80 €
450	11004	26	3,8	260,30 €	299,80 €
500	11005	30	3,8	295,80 €	341,30 €
550	11006	32	4,6	365,70 €	424,50 €
600	11007	36	4,6	409,20 €	475,30 €
625	11008	36	4,6	423,40 €	489,50 €
650	11009	38	4,6	481,70 €	514,80 €
700	11010	40	4,6	514,70 €	547,10 €
750	11011	44	4,6	586,30 €	632,00 €
800	11012	46	4,6	593,40 €	638,50 €
900	11013	46	4,6	681,10 €	727,60 €

Feuerfest ⇒ Normalkern (Eng verzahnt)

Schamotte, Feuerfest Materialien, Korund •
fire clay, refractory materials, corundum

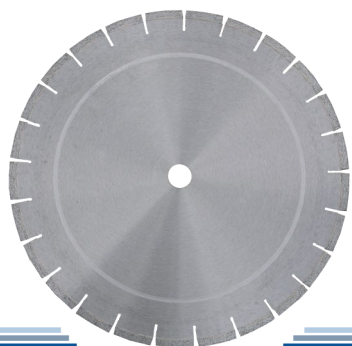

Ø	Art.-Nr.	Segment Anzahl	Segment Breite	Belaghöhe 6+1 mm	Belaghöhe 9+1 mm
300	11101	21	2,8	179,30 €	197,00 €
350	11102	25	2,8	221,30 €	246,10 €
400	11103	28	3,6	262,80 €	294,50 €
450	11104	32	3,8	319,50 €	357,70 €
500	11105	36	3,8	356,10 €	399,20 €
550	11106	40	4,6	453,40 €	512,30 €
600	11107	42	4,6	479,50 €	541,20 €
625	11108	42	4,6	494,20 €	555,40 €
650	11109	44	4,6	565,00 €	631,20 €
700	11110	50	4,6	627,40 €	698,90 €
750	11111	52	4,6	702,20 €	779,00 €
800	11112	57	4,6	754,90 €	835,40 €

Diamanttrennscheiben ⇒ Nassschnitt (wet cut) Tischsäge Feuerfest - table saw refractory

Feuerfest ⇒ Leisekern (Normal verzahnt)

Schamotte, Feuerfest Materialien, Korund •
fire clay, refractory materials, corundum

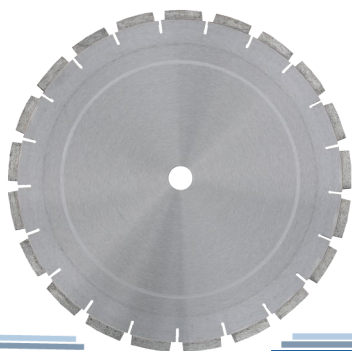

∅	Art.-Nr.	Segment Anzahl	Segment Breite	Belaghöhe 6+1 mm	Belaghöhe 9+1 mm
300	11201	18	2,8	180,10 €	198,90 €
350	11202	21	3,2	230,60 €	255,60 €
400	11203	24	3,6	263,90 €	296,10 €
450	11204	26	3,8	312,50 €	349,30 €
500	11205	30	3,8	350,90 €	393,40 €
550	11206	32	4,6	453,20 €	508,00 €
600	11207	36	4,6	538,60 €	600,30 €
625	11208	36	4,6	550,40 €	612,10 €
650	11209	38	5,0	622,40 €	676,00 €
700	11210	40	5,0	649,00 €	703,70 €
750	11211	44	5,5	778,90 €	849,10 €
800	11212	46	5,5	837,20 €	906,10 €
900	11213	52	6,0	1.035,80 €	1.156,90 €

Feuerfest ⇒ Leisekern (Eng verzahnt)

Schamotte, Feuerfest Materialien, Korund •
fire clay, refractory materials, corundum

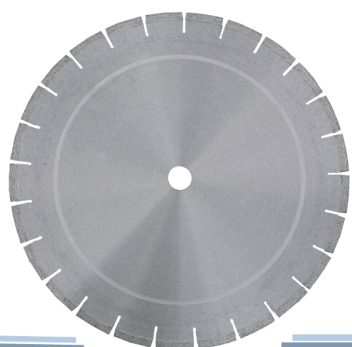

∅	Art.-Nr.	Segment Anzahl	Segment Breite	Belaghöhe 6+1 mm	Belaghöhe 9+1 mm
300	11301	21	2,8	200,70 €	229,70 €
350	11302	25	3,2	259,20 €	286,00 €
400	11303	28	3,6	293,80 €	329,20 €
450	11304	32	3,8	358,10 €	403,40 €
500	11305	36	3,8	396,50 €	443,70 €
550	11306	40	4,6	521,40 €	599,70 €
600	11307	42	4,6	589,80 €	654,60 €
625	11308	42	4,6	601,60 €	665,30 €
650	11309	44	5,0	719,10 €	776,10 €
700	11310	50	5,0	755,60 €	836,60 €
750	11311	52	5,5	846,30 €	972,90 €
800	11312	57	5,5	927,60 €	1.066,30 €

Diamanttrennscheiben

⇒ **Trocken- u. Nassschnitt - dry and wet cut**

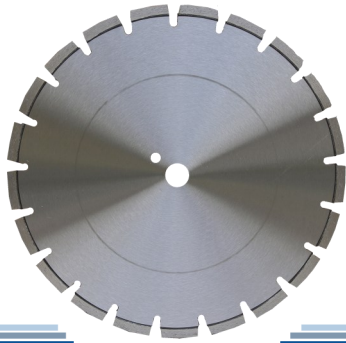

Beton Laser Premium

⇒ **Type: K-BL**

Beton (armiert), Waschbeton, Dachpfannen, Ziegel, Klinker •
reinforced concrete, aggregated concrete, roof tiles, bricks, clinker

Ø	Art.-Nr.	Segment Anzahl	Segment Breite mm	Bohrung mm	Belaghöhe 13 mm
115	602001	8	2,4	22,2	32,60 €
125	602002	9	2,4	22,2	36,60 €
150	602003	11	2,4	22,2	37,90 €
180	602004	13	2,4	22,2	43,90 €
230	602005	16	2,6	22,2	49,90 €
300	602006	18	2,8	20/25,4/30	97,60 €
350	602007	21	3,2	20/25,4/30	117,60 €
400	602008	24	3,2	25,4	164,50 €
450	602009	25	3,6	25,4	182,00 €
500	602010	30	3,6	25,4	252,00 €
600	602011	35	4,0	25,4	311,50 €

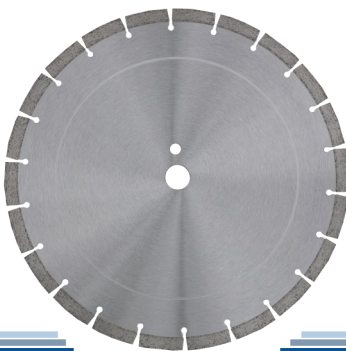

Beton Laser Standard

⇒ **Type: K-BEL**

Beton (armiert), Waschbeton, Dachpfannen, Ziegel, Klinker •
reinforced concrete, aggregated concrete, roof tiles, bricks, clinker

Ø	Art.-Nr.	Segment Anzahl	Segment Breite mm	Bohrung mm	Belaghöhe 10 mm
115	603001	9	2,0	22,2	14,50 €
125	603002	10	2,1	22,2	16,20 €
150	603003	12	2,2	22,2	25,60 €
180	603004	14	2,3	22,2	31,00 €
230	603005	16	2,5	22,2	35,10 €
300	603006	21	2,8	20/25,4/30	75,50 €
350	603007	24	3,0	20/25,4/30	89,00 €
400	603008	28	3,6	25,4	134,90 €
450	603009	32	3,6	25,4	161,90 €
500	603010	36	4,0	25,4	237,50 €
600	603011	42	4,6	25,4	267,20 €

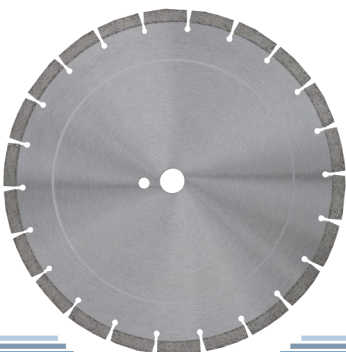

Beton Sinter Standard

⇒ **Type: K-BES**

Beton, Stahlbeton, allgemeine Baumaterialien •
concrete, reinforced concrete, general building materials

Ø	Art.-Nr.	Segment Anzahl	Segment Breite mm	Bohrung mm	Belaghöhe 12 mm
115	604001	8	1,9	22,2	14,10 €
125	604002	9	1,9	22,2	15,90 €
150	604003	12	1,9	22,2	23,70 €
180	604004	14	2,2	22,2	29,70 €
230	604005	16	2,6	22,2	42,10 €
300	604006	18	2,8	20/25,4/30	51,20 €
350	604007	22	3,0	20/25,4/30	62,70 €
400	604008	24	3,2	25,4	97,10 €

Diamanttrennscheiben

⇒ Trocken- u. Nassschnitt - dry and wet cut

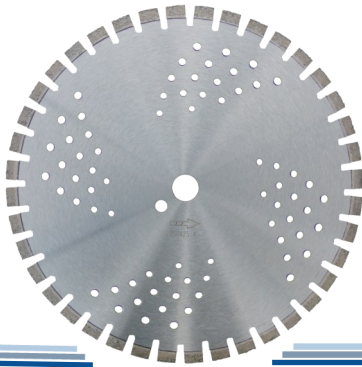

Pro Cut Premium

⇒ Type: K-BCL

Granit, Hartgestein, Beton, Stahlbeton, harte Klinker, Ziegel •
granite, hardrock, concrete, reinforced concrete, clinker bricks, bricks

Ø	Art.-Nr.	Segment Anzahl	Segment Breite	Bohrung	Belaghöhe 12 mm
115	649001	12	2,2	22,2	22,10 €
125	649002	13	2,2	22,2	24,80 €
150	649007	16	2,4	22,2	35,00 €
180	649008	20	2,6	22,2	39,00 €
230	649003	26	2,8	22,2	44,40 €
300	649004	36	3,2	20/25,4/30	82,40 €
350	649005	40	3,2	20/25,4/30	99,40 €
400	649006	46	3,4	20/25,4	128,10 €
450	649009	50	3,4	25,4	159,00 €

Red Line Turbo

⇒ Type: K-RLT

Beton, Stahlbeton, Granit, Klinker, Dachpfannen, usw. •
concrete, reinforced concrete, granite, bricks, roof tiles



Ø	Art.-Nr.	Segment Anzahl	Segment Breite mm	Bohrung mm	Belaghöhe 10 mm
115	643001	-	2,2	22,2	19,90 €
115-FL*	643002	-	2,2	M14	33,50 €
125	643003	-	2,2	22,2	22,90 €
125-FL*	643004	-	2,2	M14	35,90 €
150	643005	-	2,2	22,2	33,90 €
150-FL*	643006	-	2,2	M14	48,50 €
230	643007	-	2,6	22,2	53,50 €
230-FL*	643008	-	2,6	M14	72,50 €
300	643009	-	2,8	20/25,4/30	99,90 €
350	643010	-	3,0	20/25,4/30	124,90 €

*FL = Mit Flansch

Speed Cut Premium

⇒ Type: K-SC

Stahlbeton, Granit, Quadrostein, Gußrohre, Hartgestein, harte Klinker •
reinforced concrete, granite, hardrock, clinker bricks

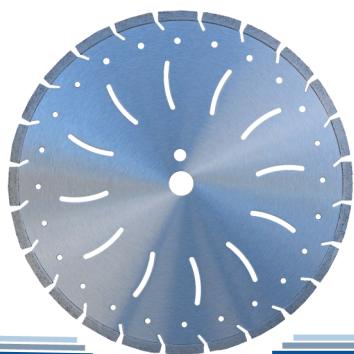

Ø	Art.-Nr.	Segment Anzahl	Segment Breite	Bohrung	Belaghöhe 10 mm
115	607001	8	2,0	22,2	30,30 €
125	607002	9	2,0	22,2	35,40 €
150	607003	12	2,4	22,2	40,40 €
180	607004	14	2,6	22,2	45,50 €
230	607005	15	2,6	22,2	55,60 €
250	607012	17	3,0	25,4	86,60 €
300	607006	21	3,0	20/25,4/30	113,80 €
350	607007	24	3,0	20/25,4/30	126,50 €
400	607008	28	3,6	25,4	174,90 €

Diamanttrennscheiben

⇒ **Trocken- u. Nassschnitt - dry and wet cut**

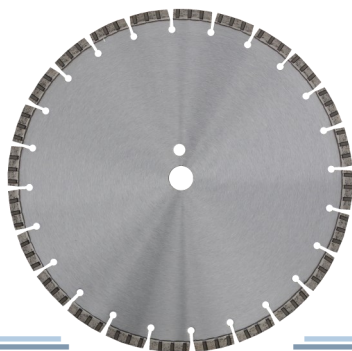

Master Cut Standard

⇒ **Type: K-MCE**

Beton, Stahlbeton, allgemeine Baumaterialien •
concrete, reinforced concrete, general building materials

Ø	Art.-Nr.	Segment Anzahl	Segment Breite	Bohrung	Belaghöhe 10 mm
115	608001	9	2,4	22,2	18,90 €
125	608002	10	2,4	22,2	21,60 €
150	608010	12	2,4	22,2	22,90 €
180	608011	14	2,6	22,2	24,30 €
230	608003	16	2,6	22,2	27,00 €
300	608004	21	3,2	20/25,4/30	56,30 €
350	608005	24	3,2	20/25,4/30	62,90 €
400	608006	28	3,4	25,4	126,80 €
450	608007	32	3,6	25,4	143,00 €
500	608008	36	3,6	25,4	183,50 €
600	608009	42	4,2	25,4	237,50 €

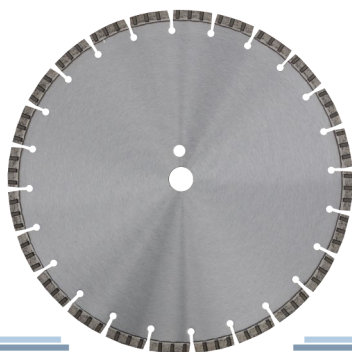

Turbo Cut Premium

⇒ **Type: K-TC**

Beton, Stahlbeton, Granit, Ziegel, Klinker, Waschbeton •
concrete, reinforced concrete, granite, bricks, clinker, aggregated concrete

Ø	Art.-Nr.	Segment Anzahl	Segment Breite	Bohrung	Belaghöhe 10 mm
115	609001	9	2,4	22,2	20,30 €
125	609002	10	2,4	22,2	25,30 €
150	609003	12	2,4	22,2	32,90 €
180	609004	14	2,6	22,2	37,90 €
230	609005	16	2,6	22,2	44,20 €
300	609006	21	3,2	20/25,4/30	88,50 €
350	609007	24	3,2	20/25,4/30	101,20 €
380	609008	26	3,4	25,4	126,50 €
400	609009	28	3,4	25,4	139,20 €
450	609010	32	3,6	25,4	164,50 €
500	609011	36	3,6	25,4	194,80 €
550	609012	38	4,0	25,4	222,70 €
600	609013	42	4,0	25,4/60	366,90 €
650	609014	42	4,2	60	430,20 €
700	609015	45	4,6	60	501,10 €
800	609016	52	4,8	60	569,40 €
900	609017	60	5,0	60	746,60 €



Beton Asphalt Kombi

⇒ **Type: K-BAK**

Beton, Asphalt, Baumaterialien •
concrete, asphalt, general building materials

Ø	Art.-Nr.	Segment Anzahl	Segment Breite	Bohrung	Belaghöhe 10 mm
300	645001	20	2,8	20/25,4	78,30 €
350	645002	22	3,0	20/25,4	89,00 €
400	645003	27	3,2	25,4	149,40 €
450	645004	30	3,4	25,4	164,50 €

Diamanttrennscheiben

⇒ Trocken- u. Nassschnitt - dry and wet cut



Asphalt Laser Premium

⇒ Type: K-AL

Asphalt, abrasive Materialien, Kalksandstein •
asphalt, abrasive materials, sand-lime brick

Ø	Art.-Nr.	Segment Anzahl	Segment Breite	Bohrung	Belaghöhe 10 mm
300	611001	21	3,2	20/25,4/30	102,50 €
350	611002	24	3,2	20/25,4/30	126,80 €
400	611003	28	3,6	25,4	167,30 €
450	611004	32	3,6	25,4	202,40 €
500	611005	36	3,6	25,4	280,70 €
600	611006	42	4,6	25,4	337,50 €
650	611007	42	4,6	25,4	351,00 €
700	611008	45	4,6	25,4	378,00 €
750	611009	45	4,6	25,4	392,00 €
800	611010	52	4,8	25,4	405,00 €
900	611011	56	5,0	25,4	599,00 €



Asphalt Laser Standard

⇒ Type: K-ALE

Asphalt abrasive Materialien, Kalksandstein •
asphalt, abrasive materials, sand-lime brick

Ø	Art.-Nr.	Segment Anzahl	Segment Breite	Bohrung	Belaghöhe 10 mm
300	612001	18	2,8	20/25,4/30	81,70 €
350	612002	21	3,0	20/25,4/30	97,50 €
400	612003	24	3,6	25,4	122,80 €
450	612004	27	3,6	25,4	182,20 €
500	612005	30	4,0	25,4	230,80 €
600	612006	36	4,6	25,4	303,30 €



Abrasive Premium mit Kernschutz

⇒ Type: K-LSP

Sandstein, Kalksandstein, Abrasive Materialien •
sandstone, sand-lime brick, abrasive materials

Ø	Art.-Nr.	Segment Anzahl	Segment Breite	Bohrung	Belaghöhe 10 mm
115	613001	9	2,0	22,2	35,40 €
125	613002	10	2,1	22,2	39,20 €
230	613006	16	2,6	22,2	83,50 €



Abrasive Standard

⇒ Type: K-LS

Sandstein, Kalksandstein, Abrasive Materialien •
sandstone, sand-lime brick, abrasive materials

Ø	Art.-Nr.	Segment Anzahl	Segment Breite	Bohrung	Belaghöhe 7 mm
115	614001	9	2,0	22,2	18,20 €
125	614002	10	2,1	22,2	21,20 €
150	614003	12	2,2	22,2	27,30 €
180	614004	14	2,3	22,2	37,90 €
230	614005	16	2,5	22,2	45,50 €

Diamanttrennscheiben

⇒ Trocken- u. Nassschnitt - dry and wet cut

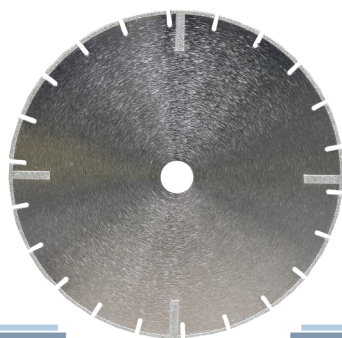

Galvanisch

⇒ Type: K-GA

Fliesen, Keramik, Marmor, Kunststoff, Glasfaser •
tiles, ceramics, marble, synthetic materials, fibreglass

Ø	Art.-Nr.	Segment Breite	Bohrung	Belaghöhe Galvanisch
115	615001	2,0	22,2	16,40 €
125	615002	2,0	22,2	17,60 €
150	615003	2,5	22,2	21,20 €
180	615004	2,8	22,2	27,30 €
200	615005	2,8	22,2	39,40 €
230	615006	2,8	22,2	32,80 €
300	615007	3,0	20	94,50 €
350	615008	3,0	20	124,00 €

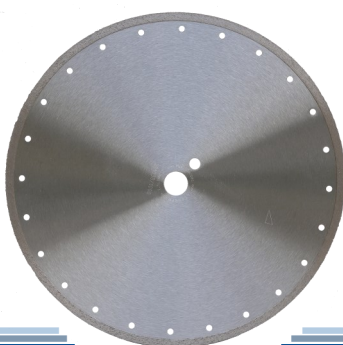

Fliesen Vollrand Profi

⇒ Type: K-FL

Fliesen, Keramik, Marmor, Granit •
tiles, ceramics, marble, granite

Ø	Art.-Nr.	Segment Breite	Bohrung	Belaghöhe 7 mm
115	616001	1,6	22,2	15,90 €
125	616002	1,6	22,2	18,20 €
150	616003	1,8	22,2	20,50 €
180	616004	1,8	22,2	25,00 €
200	616005	2,0	22,2/25,4	34,40 €
230	616007	2,0	22,2/25,4/30	44,50 €
250	616008	2,0	25,4	54,60 €
300*	616009	2,0	25,4	97,80 €
350*	616010	2,0	25,4	124,80 €

* Ø 300 und 350 Nur Nassschnitt



Red Line

⇒ Type: K-RL

Fliesen, Feinsteinzeug, Keramik, Granit, Marmor •
tiles, hard tile, ceramics, granite, marble

Ø	Art.-Nr.	Segment Breite	Bohrung	Belaghöhe 5 mm
115	617001	1,5	22,2	21,50 €
125	617002	1,5	22,2	26,50 €
150	617003	1,5	22,2	36,20 €
180	617004	1,5	22,2	43,40 €
200	617005	1,5	22,2/25,4	46,40 €
230	617006	1,5	22,2/25,4/30	56,10 €
250	617007	1,5	25,4	66,20 €

Diamanttrennscheiben

⇒ Trocken- u. Nassschnitt - dry and wet cut



Profi Cut

⇒ Type: K-PC

Fliesen, Feinsteinzeug, Keramik, Granit etc. • tiles, hard tile, ceramics, etc.

∅	Art.-Nr.	Segment Anzahl	Segment Breite	Bohrung	Belaghöhe 10 mm
115	651001	-	1,2	22,2	21,20 €
125	651002	-	1,2	22,2	23,30 €

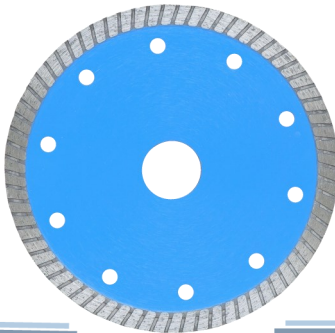

Fliesen Turbo Premium

⇒ Type: K-HFS Blau

Fliesen, Feinsteinzeug, Keramik, Granit, Marmor etc. • tiles, hard tile, ceramics, granite, marble etc.

∅	Art.-Nr.	Segment Anzahl	Segment Breite	Bohrung	Belaghöhe 7 mm
115	619001	-	1,2	22,2	21,20 €
125	619002	-	1,2	22,2	23,30 €
150	619003	-	1,9	22,2	36,40 €
180	619004	-	1,9	22,2	42,50 €
200	619005	-	1,9	25,4	54,60 €
230	619006	-	1,9	22,2	57,70 €
250	619007	-	2,2	25,4	82,00 €
300	619008	-	2,2	25,4	109,30 €
350	619009	-	2,2	25,4	124,50 €

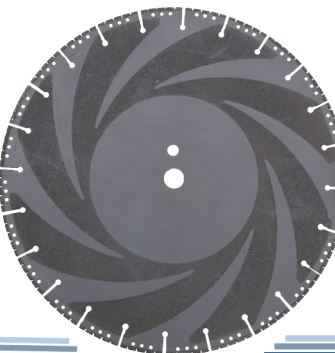

Allcut Premium

⇒ Type: K-ACP

Stahlbeton, Naturstein, Stahl, Holz, Glas, Kunststoff • reinforced concrete, natural stone, steel, wood, glass, synthetic materials

∅	Art.-Nr.	Segment Anzahl	Segment Breite	Bohrung	Preis
115	620001	8	2,6	22,2	43,80 €
125	620002	9	2,6	22,2	54,40 €
180	620003	14	2,6	22,2	92,30 €
230	620004	16	3,0	22,2	104,40 €
300	620005	21	3,0	20	152,80 €
350	620006	24	3,0	20/25,4	190,10 €

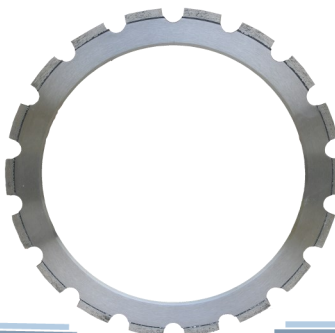

Partnerringe Stahlbeton

⇒ Type: K-PRB

Stahlbeton, harte Materialien • reinforced concrete, hard materials

Partnerringe Mauerwerk

⇒ Type: K-PRA

Mauerwerk, abrasive Materialien • masonry, abrasive materials

∅	Art.-Nr.	Segment Anzahl	Segment Breite	Anwendung	Belaghöhe 10 mm
350	621001	22	4,3	Beton	145,70 €
350	621002	22	4,3	Abrasive	145,70 €

Diamanttrennscheiben ⇒ Nassschnitt (wet cut) Granit Normalkern - granite

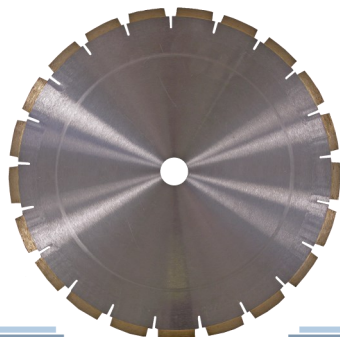

Granit ⇒ Normalkern (Normal verzahnt)

Granit, Hartgestein • granite, hardrock

∅	Art.-Nr.	Segment Anzahl	Segment Breite	Belaghöhe 7+1 mm	Belaghöhe 9+1 mm
250	11401	15	2,8	87,40 €	98,80 €
275	11402	17	2,8	94,00 €	103,50 €
300	11403	18	2,8	95,90 €	110,20 €
350	11404	21	2,8	114,90 €	133,90 €
380	11405	24	3,6	138,70 €	152,90 €
400	11406	24	3,6	140,60 €	154,80 €
450	11407	26	3,8	166,20 €	186,20 €
500	11408	30	3,8	197,60 €	209,90 €

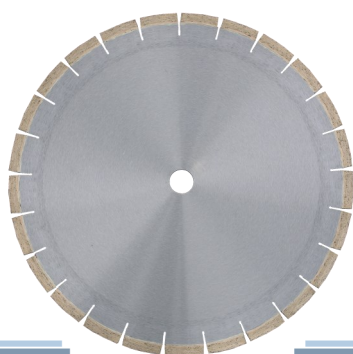

Granit ⇒ Normalkern (Eng verzahnt)

Granit, Hartgestein • granite, hardrock

∅	Art.-Nr.	Segment Anzahl	Segment Breite	Belaghöhe 7+1 mm	Belaghöhe 9+1 mm
250	11501	17	2,8	106,40 €	117,80 €
275	11502	20	2,8	113,00 €	122,50 €
300	11503	21	2,8	117,80 €	133,00 €
350	11504	25	2,8	141,50 €	159,60 €
380	11505	28	3,6	166,20 €	172,90 €
400	11506	28	3,6	169,10 €	192,80 €
450	11507	32	3,8	201,40 €	237,50 €
500	11508	36	3,8	232,70 €	264,10 €

Diamanttrennscheiben \Rightarrow Nassschnitt (wet cut) Granit Leisekern - granite silent core



Granit \Rightarrow Leisekern (Normal verzahnt)

Granit, Hartgestein • granite, hardrock

\emptyset	Art.-Nr.	Segment Anzahl	Segment Breite	Belaghöhe 7+1 mm	Belaghöhe 9+1 mm
300	11603	18	2,8	126,30 €	137,70 €
350	11604	21	3,2	152,90 €	166,20 €
380	11605	24	3,6	180,50 €	204,20 €
400	11606	24	3,6	180,50 €	204,20 €
450	11607	26	3,8	216,60 €	227,00 €
500	11608	30	3,8	251,70 €	274,50 €

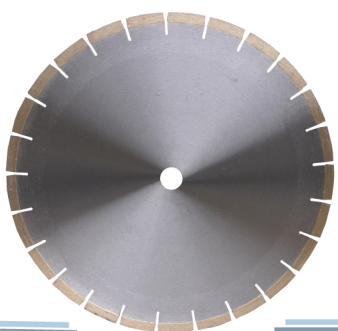

Granit \Rightarrow Leisekern (Eng verzahnt)

Granit, Hartgestein • granite, hardrock

\emptyset	Art.-Nr.	Segment Anzahl	Segment Breite	Belaghöhe 7+1 mm	Belaghöhe 9+1 mm
300	11703	21	2,8	149,10 €	161,50 €
350	11704	25	3,2	179,50 €	194,70 €
380	11705	28	3,6	208,00 €	234,70 €
400	11706	28	3,6	208,00 €	234,60 €
450	11707	32	3,8	251,70 €	286,90 €
500	11708	36	3,8	284,00 €	317,30 €

Diamanttrennscheiben ⇒ Nassschnitt (wet cut) Granit Normalkern - granite

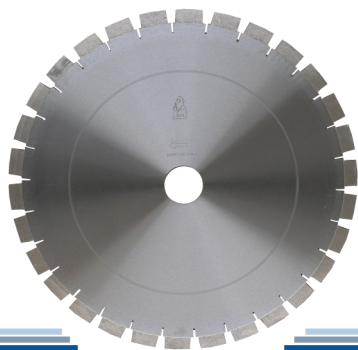

Granit ⇒ Normalkern (Normal verzahnt)

Granit, Hartgestein • granite, hardrock

Ø	Art.-Nr.	Segment Anzahl	Segment Breite	Belaghöhe		
				10 mm	15 mm	20 mm
400	11801	24	3,6	162,70 €	184,80 €	224,50 €
450	11802	26	3,8	191,70 €	217,40 €	262,20 €
500	11803	30	3,8	216,90 €	246,30 €	297,70 €
550	11804	32	4,6	265,00 €	301,80 €	362,50 €
600	11805	36	4,6	296,10 €	337,30 €	405,60 €
625	11806	36	4,6	309,30 €	351,50 €	420,70 €
650	11807	38	5,0	380,60 €	431,50 €	511,80 €
700	11808	40	5,0	411,00 €	464,60 €	548,50 €
750	11809	44	5,5	518,90 €	586,70 €	689,60 €
800	11810	46	5,5	544,20 €	613,70 €	718,50 €

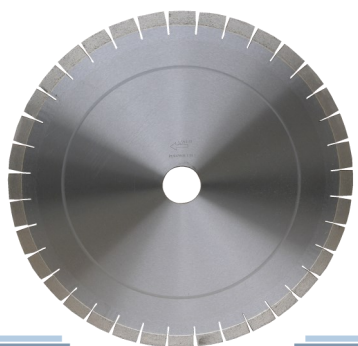

Granit ⇒ Normalkern (Eng verzahnt)

Granit, Hartgestein • granite, hardrock

Ø	Art.-Nr.	Segment Anzahl	Segment Breite	Belaghöhe		
				10 mm	15 mm	20 mm
400	11901	28	3,6	185,10 €	210,50 €	256,50 €
450	11902	32	3,8	225,50 €	256,40 €	310,80 €
500	11903	36	3,8	250,70 €	285,20 €	346,30 €
550	11904	40	4,6	314,10 €	358,90 €	433,70 €
600	11905	42	4,6	332,90 €	380,20 €	458,90 €
625	11906	42	4,6	346,20 €	394,40 €	474,00 €
650	11907	46	5,0	426,20 €	484,60 €	577,70 €
700	11908	50	5,0	476,20 €	540,50 €	642,70 €
750	11909	52	5,5	574,20 €	651,30 €	769,60 €
800	11910	57	5,5	620,20 €	702,60 €	828,50 €

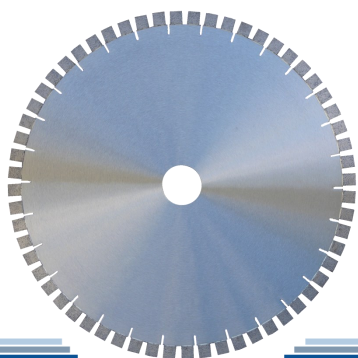

Granit ⇒ Normalkern (Kurzzahn)

Granit, Hartgestein • granite, hardrock

Ø	Art.-Nr.	Segment Anzahl	Segment Breite	Belaghöhe		
				10 mm	15 mm	20 mm
400	12001	48	3,6	185,10 €	210,50 €	256,50 €
450	12002	52	3,8	225,50 €	256,40 €	310,80 €
500	12003	60	3,8	250,70 €	285,20 €	346,30 €
550	12004	64	4,6	314,10 €	358,90 €	433,70 €
600	12005	72	4,6	332,90 €	380,20 €	458,90 €
625	12006	72	4,6	346,20 €	394,40 €	474,00 €
650	12007	76	5,0	426,20 €	484,60 €	577,70 €
700	12008	80	5,0	476,20 €	540,50 €	642,70 €
750	12009	88	5,5	574,20 €	651,30 €	769,60 €
800	12010	92	5,5	620,20 €	702,60 €	828,50 €

Diamanttrennscheiben ⇒ Nassschnitt (wet cut) Granit Leisekern - granite silence core

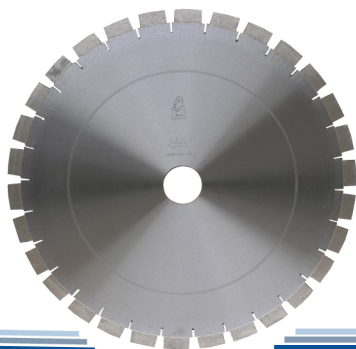

Granit ⇒ Leisekern (Normal verzahnt)

Granit, Hartgestein • granite, hardrock

Ø	Art.-Nr.	Segment Anzahl	Segment Breite	Belaghöhe		
				10 mm	15 mm	20 mm
400	12101	24	3,6	203,50 €	228,90 €	280,00 €
450	12102	26	3,8	242,60 €	272,40 €	331,00 €
500	12103	30	3,8	271,00 €	304,70 €	371,30 €
550	12104	32	4,6	349,90 €	393,50 €	475,10 €
600	12105	36	4,6	420,40 €	471,50 €	566,30 €
625	12106	36	4,6	431,30 €	483,30 €	579,30 €
650	12107	38	5,0	514,60 €	576,30 €	688,00 €
700	12108	40	5,0	538,20 €	602,30 €	718,10 €
750	12109	46	5,5	639,80 €	717,60 €	856,30 €
800	12110	46	5,5	696,80 €	779,00 €	924,30 €

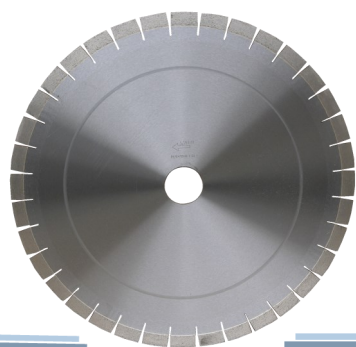

Granit ⇒ Leisekern (Eng verzahnt)

Granit, Hartgestein • granite, hardrock

Ø	Art.-Nr.	Segment Anzahl	Segment Breite	Belaghöhe		
				10 mm	15 mm	20 mm
400	12201	28	3,6	224,20 €	252,90 €	321,00 €
450	12202	32	3,8	274,00 €	308,80 €	390,30 €
500	12203	36	3,8	302,30 €	341,10 €	431,80 €
550	12204	40	4,6	395,60 €	446,90 €	561,50 €
600	12205	42	4,6	454,60 €	511,40 €	637,90 €
625	12206	42	4,6	465,60 €	523,30 €	651,40 €
650	12207	46	5,0	557,00 €	625,90 €	776,10 €
700	12208	50	5,0	598,80 €	673,10 €	835,40 €
750	12209	52	5,5	691,10 €	777,90 €	964,00 €
800	12210	57	5,5	767,40 €	862,00 €	1.064,20 €

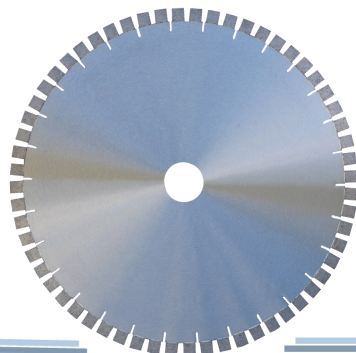

Granit ⇒ Leisekern (Kurzzahn)

Granit, Hartgestein • granite, hardrock

Ø	Art.-Nr.	Segment Anzahl	Segment Breite	Belaghöhe		
				10 mm	15 mm	20 mm
400	12301	48	3,6	224,20 €	252,90 €	321,00 €
450	12302	52	3,8	274,00 €	308,80 €	390,30 €
500	12303	60	3,8	302,30 €	341,10 €	431,80 €
550	12304	64	4,6	395,60 €	446,90 €	561,50 €
600	12305	72	4,6	454,60 €	511,40 €	637,90 €
625	12306	72	4,6	465,60 €	523,30 €	651,40 €
650	12307	76	5,0	557,00 €	625,90 €	776,10 €
700	12308	80	5,0	598,80 €	673,10 €	835,40 €
750	12309	88	5,5	691,10 €	777,90 €	964,00 €
800	12310	92	5,5	767,40 €	862,00 €	1.064,20 €

Diamanttrennscheiben ⇒ Nassschnitt (wet cut) Blocksäge - block saw

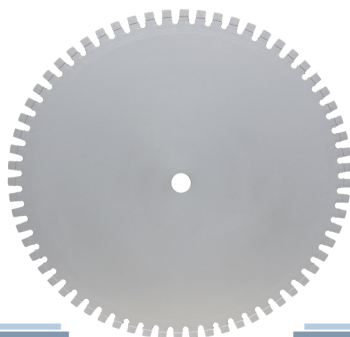

Granit Hartgestein ⇒ Normalkern

Granit • granite

Ø	Art.-Nr.	Segment Anzahl	Segment Breite	Belaghöhe	
				12 mm	20 mm
900	12401	64	6,5	958,90 €	1.281,30 €
1000	12402	70	7,0	1.140,20 €	1.507,90 €
1100	12403	74	7,0	1.341,00 €	1.729,30 €
1200	12404	80	7,0	1.519,20 €	1.952,80 €
1300	12405	88	7,5	1.839,50 €	2.317,50 €
1400	12406	92	8,0	2.139,30 €	2.671,80 €
1500	12407	100	9,0	2.397,80 €	2.976,70 €
1600	12408	104	9,0	2.668,70 €	3.271,20 €

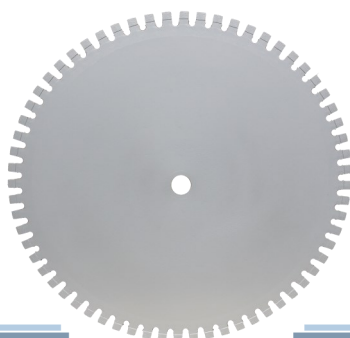

Granit Hartgestein ⇒ Leisekern

Granit • granite

Ø	Art.-Nr.	Segment Anzahl	Segment Breite	Belaghöhe	
				12 mm	20 mm
900	12501	64	6,5	1.161,80 €	1.464,60 €
1000	12502	70	7,0	1.357,50 €	1.724,20 €
1100	12503	74	7,0	1.707,70 €	2.096,00 €
1200	12504	80	7,0	1.958,00 €	2.392,60 €

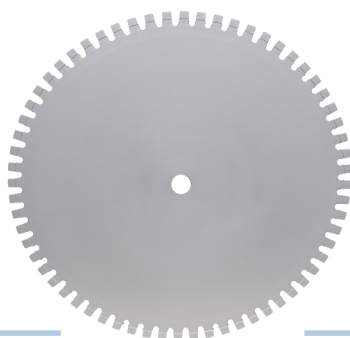

Sandstein ⇒ Normalkern

Sandstein • sandstone

Ø	Art.-Nr.	Segment Anzahl	Segment Breite	Belaghöhe	
				12 mm	20 mm
900	12601	64	6,5	1.149,40 €	1.537,70 €
1000	12602	70	7,0	1.368,80 €	1.808,68 €
1100	12603	74	7,0	1.608,80 €	2.074,40 €
1200	12604	80	7,0	1.823,10 €	2.344,20 €
1300	12605	88	7,5	2.207,20 €	2.781,00 €
1400	12606	92	8,0	2.567,70 €	3.206,30 €
1500	12607	100	9,0	2.877,80 €	3.573,00 €
1600	12608	104	9,0	3.202,20 €	3.925,30 €

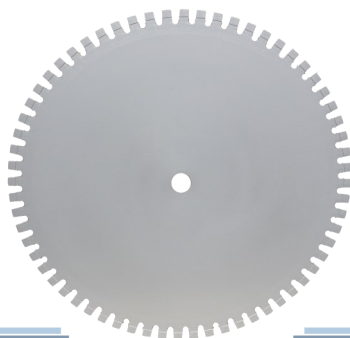

Sandstein ⇒ Leisekern

Sandstein • sandstone

Ø	Art.-Nr.	Segment Anzahl	Segment Breite	Belaghöhe	
				12 mm	20 mm
900	12701	64	6,5	1.393,50 €	1.781,90 €
1000	12702	70	7,0	1.628,40 €	2.069,20 €
1100	12703	74	7,0	2.048,60 €	2.514,20 €
1200	12704	80	7,0	2.350,40 €	2.871,60 €

Diamanttrennscheiben ⇒ Nassschnitt (wet cut) Marmor, Weichgestein - marble, soft stone

Marmor ⇒ Normalkern (Eng verzahnt)

Marmor, Weichgestein • marble, soft stone

Ø	Art.-Nr.	Segment Anzahl	Segment Breite	Belaghöhe	
				6+1 mm	9+1 mm
250	12801	17	2,8	89,60 €	108,10 €
275	12802	18	2,8	103,00 €	125,60 €
300	12803	21	2,8	113,30 €	136,90 €
350	12804	25	2,8	138,00 €	166,80 €
400	12805	28	3,6	165,80 €	196,70 €
450	12806	32	3,8	204,90 €	243,00 €
500	12807	36	3,8	234,80 €	277,00 €
550	12808	40	4,6	279,10 €	327,50 €
600	12809	42	4,6	301,70 €	353,20 €
650	12810	55	5,0	371,80 €	426,40 €
700	12811	50	5,0	420,20 €	479,90 €
750	12812	52	5,5	496,40 €	557,20 €
800	12813	57	5,5	542,80 €	606,60 €

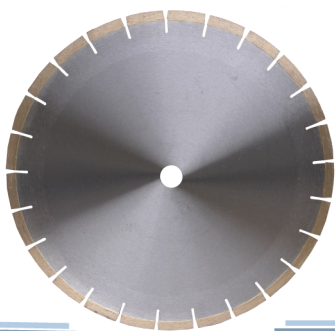

Marmor ⇒ Leisekern (Eng verzahnt)

Marmor, Weichgestein • marble, soft stone

Ø	Art.-Nr.	Segment Anzahl	Segment Breite	Belaghöhe	
				6+1 mm	9+1 mm
300	12901	21	2,8	144,20 €	160,60 €
350	12902	25	3,2	176,10 €	192,60 €
400	12903	28	3,6	200,80 €	227,60 €
450	12904	32	3,8	251,30 €	279,10 €
500	12905	36	3,8	281,10 €	310,00 €
550	12906	40	4,6	360,50 €	401,70 €
600	12907	42	4,6	400,60 €	448,00 €
650	12908	44	5,0	481,00 €	539,70 €
700	12909	50	5,0	525,30 €	594,30 €
750	12910	52	5,5	620,00 €	697,30 €
800	12911	57	5,5	671,50 €	763,20 €

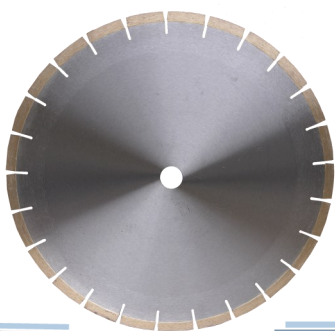

Diamanttrennscheiben ⇒ Nassschnitt (wet cut) Sandstein - sandstone

Sandstein ⇒ Normalkern

Sandstein • sandstone

Ø	Art.-Nr.	Segment Anzahl	Segment Breite	Belaghöhe		
				10 mm	15 mm	20mm
250	13001	15	2,8	116,10 €	-	-
275	13002	17	2,8	124,30 €	-	-
300	13003	18	2,8	127,40 €	-	-
350	13004	21	2,8	150,10 €	-	-
380	13005	24	3,6	179,95 €	-	-
400	13006	24	3,6	223,50 €	270,90 €	329,60 €
450	13007	26	3,8	260,60 €	314,10 €	379,00 €
500	13008	30	3,8	305,90 €	367,70 €	441,80 €
550	13009	32	4,6	357,40 €	431,50 €	519,10 €
600	13010	36	4,6	402,70 €	486,10 €	585,00 €
625	13011	36	4,6	423,30 €	506,70 €	604,60 €
650	13012	39	5,0	498,50 €	594,30 €	706,50 €
700	13013	40	5,0	534,50 €	632,40 €	747,70 €
750	13014	46	5,5	658,10 €	778,60 €	917,70 €
800	13015	46	5,5	685,90 €	806,40 €	945,50 €

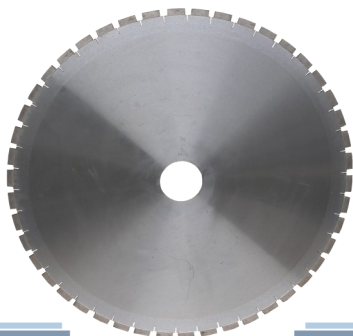

Sandstein ⇒ Leisekern

Sandstein • sandstone

Ø	Art.-Nr.	Segment Anzahl	Segment Breite	Belaghöhe		
				10 mm	15 mm	20mm
300	13101	18	2,8	165,30 €	-	-
350	13102	21	3,2	197,40 €	-	-
400	13103	24	3,6	263,60 €	311,00 €	369,70 €
450	13104	26	3,8	312,00 €	365,60 €	430,50 €
500	13105	30	3,8	355,30 €	417,10 €	492,30 €
550	13106	32	4,6	448,00 €	522,20 €	610,70 €
600	13107	36	4,6	518,00 €	601,50 €	700,40 €
625	13108	36	4,6	532,50 €	615,90 €	714,80 €
650	13109	38	5,0	622,10 €	716,80 €	829,10 €
700	13110	40	5,0	653,00 €	750,80 €	866,20 €
750	13111	46	5,5	797,20 €	917,70 €	1.056,70 €
800	13112	46	5,5	830,10 €	960,90 €	1.089,70 €

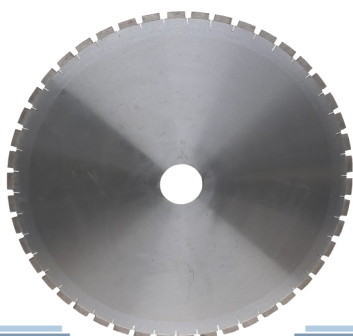

Diamantbohrkronen ⇒ Nassschnitt Diamond drill-bit (wet cut)

Stahlbeton, Mauerwerk ⇒ Nutzlänge 450 mm

reinforced concrete, masonry

Anschlüsse: 1 1/4; R1/2; 3-Loch

Ø	Art.-Nr.	Segment Anzahl	Segment Breite	Neu 7 mm	Wiederbelag 7 mm	Neu 10 mm	Wiederbelag 10 mm
32	20101	3	3,0	35,30 €	26,70 €	43,80 €	34,20 €
42	20102	3	3,5	36,50 €	26,70 €	45,10 €	34,20 €
52	20103	4	3,5	40,10 €	33,40 €	50,70 €	43,20 €
57	20104	4	3,5	42,10 €	33,40 €	52,80 €	43,20 €
62	20105	5	3,5	46,30 €	38,60 €	59,10 €	50,50 €
67	20106	5	3,5	49,00 €	38,60 €	62,10 €	50,50 €
72	20107	6	3,5	54,70 €	45,90 €	70,00 €	60,10 €
77	20144	6	3,5	59,00 €	49,90 €	78,00 €	67,00 €
82	20108	7	3,5	62,30 €	52,70 €	79,90 €	69,20 €
87	20145	7	3,5	69,50 €	57,50 €	88,00 €	76,00 €
92	20109	8	3,5	73,70 €	61,80 €	94,10 €	80,90 €
102	20110	9	3,5	82,80 €	69,10 €	105,70 €	90,50 €
107	20111	9	3,5	90,30 €	69,10 €	114,00 €	90,50 €
112	20112	9	3,5	83,50 €	69,10 €	106,50 €	90,50 €
122	20113	10	3,5	90,50 €	81,00 €	115,80 €	105,20 €
127	20114	10	3,5	99,60 €	81,00 €	125,90 €	105,20 €
132	20115	10	3,5	100,30 €	81,00 €	126,70 €	105,20 €
137	20116	10	3,5	120,30 €	81,00 €	148,90 €	105,20 €
142	20117	11	3,5	115,60 €	90,60 €	145,20 €	117,40 €
152	20118	12	4,0	117,60 €	101,70 €	150,20 €	132,70 €
157	20119	12	4,0	139,90 €	101,70 €	175,00 €	132,70 €
162	20120	12	4,0	119,50 €	101,70 €	152,40 €	132,70 €
167	20121	12	4,0	139,30 €	101,70 €	174,40 €	132,70 €
172	20122	13	4,0	145,70 €	112,70 €	183,10 €	146,40 €
178	20123	13	4,0	145,70 €	112,70 €	183,10 €	146,40 €
182	20124	13	4,0	149,10 €	112,70 €	186,90 €	146,40 €
187	20125	13	4,0	153,20 €	112,70 €	191,40 €	146,40 €
192	20126	14	4,0	159,60 €	125,90 €	200,20 €	162,80 €
202	20127	14	4,0	174,80 €	125,90 €	217,10 €	162,80 €
225	20128	15	4,0	222,50 €	163,10 €	273,40 €	207,30 €
227	20129	15	4,0	235,70 €	163,10 €	288,10 €	207,30 €
232	20130	15	4,0	235,70 €	163,10 €	288,10 €	207,30 €
250	20131	18	4,5	259,90 €	191,60 €	322,10 €	246,30 €
257	20132	18	4,5	271,40 €	191,60 €	334,80 €	246,30 €
300	20133	20	4,5	295,90 €	216,50 €	365,90 €	277,60 €
350	20134	24	4,5	343,80 €	254,10 €	426,50 €	326,80 €
400	20135	26	5,0	397,00 €	287,50 €	489,20 €	367,60 €
450	20136	28	5,0	493,20 €	342,50 €	599,80 €	432,40 €
500	20137	30	5,0	515,30 €	360,40 €	628,10 €	456,00 €
600	20138	35	5,0	583,70 €	411,70 €	713,40 €	522,30 €
700	20139	40	5,0	713,60 €	501,80 €	867,00 €	631,60 €
800	20140	45	5,0	882,30 €	558,80 €	1.063,60 €	704,20 €
900	20141	50	5,0	1.012,20 €	615,80 €	1.217,20 €	776,80 €
1000	20142	55	5,0	1.117,00 €	672,90 €	1.343,00 €	849,50 €
1200	20143	65	5,0	1.641,10 €	786,90 €	1.943,80 €	994,70 €



Andere Nutzlängen und Anschlüsse auf Anfrage lieferbar

Diamantbohrkronen ⇒ Nassschnitt Diamond drill-bit (wet cut)

Granit, Hartgestein ⇒ Nutzlänge 450 mm

granite, hardrock

Anschlüsse: 1 1/4; R1/2; 3-Loch



Ø	Art.-Nr.	Segment Anzahl	Segment Breite	Neu 7 mm	Wiederbelag 7 mm
32	20201	3	3,0	35,30 €	26,70 €
42	20202	3	3,5	36,50 €	26,70 €
52	20203	4	3,5	40,10 €	33,40 €
57	20204	4	3,5	42,10 €	33,40 €
62	20205	4	3,5	40,10 €	33,40 €
67	20206	4	3,5	42,90 €	33,40 €
72	20207	5	3,5	48,60 €	40,40 €
82	20208	5	3,5	49,90 €	40,40 €
92	20209	6	3,5	61,40 €	50,60 €
102	20210	6	3,5	64,30 €	50,60 €
107	20211	6	3,5	71,80 €	50,60 €
112	20212	6	3,5	65,10 €	50,60 €
122	20213	7	3,5	72,10 €	62,50 €
127	20214	7	3,5	81,10 €	62,50 €
132	20215	7	3,5	81,90 €	62,50 €
137	20216	7	3,5	101,90 €	62,50 €
142	20217	8	3,5	97,10 €	72,90 €
152	20218	8	4,0	92,00 €	73,90 €
157	20219	8	4,0	114,30 €	73,90 €
162	20220	8	4,0	94,00 €	73,90 €
167	20221	8	4,0	113,80 €	73,90 €
172	20222	9	4,0	120,20 €	84,90 €
178	20223	9	4,0	120,20 €	84,90 €
182	20224	9	4,0	123,60 €	84,90 €
187	20225	10	4,0	134,00 €	98,10 €
192	20226	10	4,0	134,00 €	98,10 €
202	20227	10	4,0	149,20 €	98,10 €
225	20228	11	4,5	196,10 €	136,60 €
227	20229	11	4,5	209,20 €	136,60 €
232	20230	11	4,5	209,20 €	136,60 €
250	20231	12	4,5	218,80 €	150,50 €
257	20232	12	4,5	230,30 €	150,50 €
300	20233	14	4,5	254,80 €	175,40 €
350	20234	16	4,5	289,00 €	199,30 €
400	20235	18	5,0	342,20 €	232,70 €

Andere Nutzlängen und Anschlüsse auf Anfrage lieferbar

Diamantbohrkronen ⇒ Nassschnitt Diamond drill-bit (wet cut)

Marmor, Fliesen ⇒ Nutzlänge bis 450 mm

marble, tiles

Anschlüsse: 1 1/4; R1/2



Ø	Art.-Nr.	Segment Anzahl	Segment Breite	Neu 7 mm	Wiederbelag 7 mm
32	20301	3	3,0	35,30 €	26,70 €
42	20302	3	3,5	36,50 €	26,70 €
52	20303	4	3,5	40,10 €	33,40 €
57	20304	4	3,5	42,10 €	33,40 €
62	20305	4	3,5	40,10 €	33,40 €
67	20306	4	3,5	42,90 €	33,40 €
72	20307	5	3,5	48,60 €	40,40 €
82	20308	5	3,5	49,90 €	40,40 €
92	20309	6	3,5	61,40 €	50,60 €
102	20310	6	3,5	64,30 €	50,60 €
107	20311	6	3,5	71,80 €	50,60 €
112	20312	6	3,5	65,10 €	50,60 €
122	20313	7	3,5	72,10 €	62,50 €
127	20314	7	3,5	81,10 €	62,50 €
132	20315	7	3,5	81,90 €	62,50 €
137	20316	7	3,5	101,90 €	62,50 €
142	20317	8	3,5	97,10 €	72,90 €
152	20318	8	4,0	92,00 €	73,90 €
157	20319	8	4,0	114,30 €	73,90 €
162	20320	8	4,0	94,00 €	73,90 €
167	20321	8	4,0	113,80 €	73,90 €
172	20322	9	4,0	120,20 €	84,90 €
178	20323	9	4,0	120,20 €	84,90 €
182	20324	9	4,0	123,60 €	84,90 €
187	20325	10	4,0	134,00 €	98,10 €
192	20326	10	4,0	134,00 €	98,10 €
202	20327	10	4,0	149,20 €	98,10 €
225	20328	11	4,0	196,10 €	136,60 €
227	20329	11	4,0	209,20 €	136,60 €
232	20330	11	4,0	209,20 €	136,60 €
250	20331	12	4,5	218,80 €	150,50 €
257	20332	12	4,5	230,30 €	150,50 €
300	20333	14	4,5	254,80 €	175,40 €
350	20334	16	4,5	289,00 €	199,30 €
400	20335	18	5,0	342,20 €	232,70 €

Andere Nutzlängen und Anschlüsse auf Anfrage lieferbar

Diamantbohrkronen ⇒ Nassschnitt Diamond drill-bit (wet cut)

Asphalt, Frischbeton, Abrasiv ⇒ Nutzlänge 450 mm

asphalt, fresh concrete, abrasive

Anschlüsse: 1 1/4; R1/2; 3-Loch



Ø	Art.-Nr.	Segment Anzahl	Segment Breite	Neu 7 mm	Wiederbelag 7 mm	Neu 10 mm	Wiederbelag 10 mm
32	20401	3	3,0	41,30 €	31,40 €	50,90 €	40,00 €
42	20402	3	3,5	42,60 €	31,40 €	52,30 €	40,00 €
52	20403	4	3,5	47,10 €	39,30 €	59,00 €	50,50 €
57	20404	4	3,5	49,30 €	39,30 €	61,50 €	50,50 €
62	20405	5	3,5	54,40 €	45,50 €	68,90 €	59,20 €
67	20406	5	3,5	57,60 €	45,50 €	72,40 €	59,20 €
72	20407	6	3,5	64,40 €	54,20 €	81,70 €	70,50 €
82	20408	7	3,5	73,30 €	62,30 €	93,30 €	81,20 €
92	20409	8	3,5	86,70 €	73,00 €	109,80 €	94,80 €
102	20410	9	3,5	97,30 €	81,60 €	123,40 €	106,20 €
107	20411	9	3,5	105,90 €	81,60 €	132,80 €	106,20 €
112	20412	9	3,5	98,20 €	81,60 €	124,30 €	106,20 €
122	20413	10	3,5	106,50 €	95,50 €	135,30 €	123,20 €
127	20414	10	3,5	116,90 €	95,50 €	146,70 €	123,20 €
132	20415	10	3,5	117,70 €	95,50 €	147,60 €	123,20 €
137	20416	10	3,5	140,70 €	95,50 €	172,80 €	123,20 €
142	20417	11	3,5	135,50 €	106,80 €	169,00 €	137,40 €
152	20418	12	4,0	138,50 €	120,30 €	175,70 €	155,80 €
157	20419	12	4,0	164,10 €	120,30 €	203,80 €	155,80 €
162	20420	12	4,0	140,70 €	120,30 €	178,20 €	155,80 €
167	20421	12	4,0	163,50 €	120,30 €	203,10 €	155,80 €
172	20422	13	4,0	171,10 €	133,20 €	213,50 €	171,90 €
178	20423	13	4,0	171,10 €	133,20 €	213,50 €	171,90 €
182	20424	13	4,0	175,00 €	133,20 €	217,80 €	171,90 €
187	20425	13	4,0	179,60 €	133,20 €	222,90 €	171,90 €
192	20426	14	4,0	187,30 €	148,60 €	233,20 €	190,80 €
202	20427	14	4,0	204,70 €	148,60 €	252,40 €	190,80 €
225	20428	15	4,0	260,40 €	192,10 €	317,50 €	242,70 €
227	20429	15	4,0	275,50 €	192,10 €	334,10 €	242,70 €
232	20430	15	4,0	275,50 €	192,10 €	334,10 €	242,70 €
250	20431	18	4,5	299,60 €	221,20 €	366,90 €	280,90 €
257	20432	18	4,5	312,70 €	221,20 €	381,30 €	280,90 €
300	20433	20	4,5	347,00 €	255,80 €	426,00 €	325,90 €
350	20434	24	4,5	403,50 €	300,50 €	497,00 €	384,00 €
400	20435	26	5,0	465,20 €	339,60 €	569,20 €	431,40 €
450	20436	28	5,0	576,40 €	403,40 €	695,70 €	506,00 €
500	20437	30	5,0	602,50 €	424,70 €	728,90 €	533,80 €
600	20438	35	5,0	682,90 €	485,40 €	828,40 €	611,80 €
700	20439	40	5,0	833,80 €	590,60 €	1.005,30 €	738,50 €
800	20440	45	5,0	1.029,30 €	657,90 €	1.231,00 €	823,70 €
900	20441	50	5,0	1.180,20 €	725,20 €	1.407,90 €	908,80 €
1000	20442	55	5,0	1.302,50 €	792,50 €	1.553,30 €	994,00 €
1200	20443	65	5,0	1.907,80 €	927,10 €	2.239,90 €	1.164,30 €

Andere Nutzlängen und Anschlüsse auf Anfrage lieferbar

Diamantbohrkronen ⇒ Trockenschnitt Diamond drill-bit (dry cut)



Mauerwerk ⇒ Nutzlänge 450 mm Div. Anschlüsse

masonry

Ø	Art.-Nr.	Segment Anzahl	Segment Breite	Neu 7 mm	Wiederbelag 7 mm
32	20501	3	3,0	34,00 €	26,60 €
42	20502	3	3,5	35,10 €	26,60 €
52	20503	3	3,5	32,70 €	26,60 €
57	20504	3	3,5	34,60 €	26,60 €
62	20505	3	3,5	32,70 €	26,60 €
67	20506	4	3,5	41,30 €	34,70 €
72	20507	4	3,5	40,80 €	34,70 €
82	20508	4	3,5	42,20 €	34,70 €
92	20509	4	3,5	47,20 €	34,70 €
102	20510	5	3,5	56,00 €	45,00 €
107	20511	5	3,5	63,20 €	45,00 €
112	20512	5	3,5	56,70 €	45,00 €
122	20513	6	3,5	63,50 €	53,10 €
127	20514	6	3,5	72,20 €	53,10 €
132	20515	6	3,5	72,90 €	53,10 €
137	20516	6	3,5	92,10 €	53,10 €
142	20517	6	3,5	81,70 €	53,10 €
152	20518	6	4,0	76,30 €	54,50 €
158	20519	7	4,0	103,90 €	67,20 €
162	20520	7	4,0	84,30 €	67,20 €
167	20521	7	4,0	103,40 €	67,20 €
172	20522	7	4,0	103,40 €	67,20 €
178	20523	8	4,0	109,60 €	79,90 €
182	20524	8	4,0	112,80 €	79,90 €
187	20525	8	4,0	116,70 €	79,90 €
192	20526	8	4,0	116,70 €	79,90 €
202	20527	8	4,0	131,40 €	79,90 €
225	20528	9	4,0	169,00 €	93,50 €
250	20529	10	4,0	208,00 €	105,50 €



Mauerwerk ⇒ Nutzlänge 200/300 mm Bajonett Anschluss

masonry

Ø	Art.-Nr.	Segment Anzahl	Segment Breite	Neu 7 mm	Wiederbelag 7 mm
52	20601	3	3,5	62,50 €	26,60 €
62	20602	3	3,5	64,70 €	26,60 €
67	20603	3	3,5	73,30 €	26,60 €
72	20604	4	3,5	72,60 €	34,70 €
82	20605	4	3,5	74,80 €	34,70 €
92	20606	4	3,5	74,40 €	34,70 €
102	20607	5	3,5	83,00 €	45,00 €
112	20608	5	3,5	87,00 €	45,00 €
122	20609	5	3,5	91,30 €	45,00 €
132	20610	5	3,5	95,60 €	45,00 €
152	20611	5	4,0	116,00 €	47,00 €
162	20612	6	4,0	130,70 €	53,10 €
172	20613	6	4,0	139,20 €	53,10 €
182	20614	6	4,0	145,70 €	53,10 €
202	20615	7	4,0	162,50 €	67,20 €

Bohrkronen mit Ringsegmenten ⇒ Nassschnitt Diamond drill-bit (with ring-segments)



Stahlbeton ⇒ Nutzlänge bis 400 mm R1/2

concrete, reinforced concrete

Ø	Art.-Nr.	Segment Breite	Preis
10	207001	2,5	51,70 €
12	207002	2,5	52,00 €
14	207003	2,5	53,30 €
16	207004	2,5	54,10 €
17	207005	2,5	54,60 €
18	207006	2,5	54,90 €
20	207007	2,5	56,60 €
22	207008	2,5	57,10 €
24	207009	2,5	57,90 €
25	207010	2,5	59,20 €
28	207011	2,5	60,40 €
30	207012	2,5	61,50 €
32	207013	2,5	64,20 €
35	207014	3,0	72,60 €
40	207015	3,0	81,90 €



Granit ⇒ Nutzlänge bis 400 mm R1/2

granite

Ø	Art.-Nr.	Segment Breite	Preis
10	208001	2,5	51,70 €
12	208002	2,5	52,00 €
14	208003	2,5	53,30 €
16	208004	2,5	54,10 €
17	208005	2,5	54,60 €
18	208006	2,5	54,90 €
20	208007	2,5	56,60 €
22	208008	2,5	57,10 €
24	208009	2,5	57,90 €
25	208010	2,5	59,20 €
28	208011	2,5	60,40 €
30	208012	2,5	61,50 €
32	208013	2,5	64,20 €
35	208014	3,0	72,60 €
40	208015	3,0	81,90 €



Abrasiv ⇒ Nutzlänge bis 400 mm R1/2

abrasive materials

Ø	Art.-Nr.	Segment Breite	Preis
10	209001	2,5	56,80 €
12	209002	2,5	57,20 €
14	209003	2,5	58,60 €
16	209004	2,5	59,50 €
17	209005	2,5	60,00 €
18	209006	2,5	60,40 €
20	209007	2,5	62,20 €
22	209008	2,5	62,80 €
24	209009	2,5	63,70 €
25	209010	2,5	65,10 €
28	209011	2,5	66,40 €
30	209012	2,5	67,60 €
32	209013	2,5	70,60 €
35	209014	3,0	79,90 €
40	209015	3,0	90,10 €

Andere Nutzlängen und Anschlüsse auf Anfrage lieferbar

Dosensenker Segmente Lasergeschweißt



Type: „Black Star“ Standard (Anschluss M16)

Mauerwerk, Kalksandstein
masonry, sand-lime brick

Ø	Art.-Nr.	Anzahl Segment	Belag Höhe	Preis
68	626001	3	8	26,60 €
82	626003	4	8	28,00 €



Type: „White Star“ Premium (Anschluss M16)

Mauerwerk, harter Kalksandstein, Quadrostein
masonry, hard sand-lime brick

Ø	Art.-Nr.	Anzahl Segment	Belag Höhe	Preis
68	627001	6	8	47,30 €
82	627002	10	8	54,50 €
mit Absauglöcher im Deckel für Staubabsaugung				
68	627009	4	8	47,30 €
82	627010	6	8	54,50 €



Type: „Red Star“ Premium (Anschluss M16)

Beton, Stahlbeton, Mauerwerk, harter Kalksandstein
concrete, reinforced concrete, masonry, hard sand-lime brick

Ø	Art.-Nr.	Anzahl Segment	Belag Höhe	Preis
68	628001	3	8	45,50 €
82	628002	4	8	51,60 €
mit Absauglöcher im Deckel für Staubabsaugung				
68	628003	4	8	45,50 €
82	628003	6	8	51,60 €



Type: „Blue Star“ Dachsegment Premium (Anschluss M16)

Beton, Stahlbeton, Mauerwerk, harter Kalksandstein
concrete, reinforced concrete, masonry, hard sand-lime brick

Ø	Art.-Nr.	Anzahl Segment	Belag Höhe	Preis
68	629001	4	10	48,50 €
82	629002	5	10	54,60 €

Aufnahmeschaft und Zentrierbohrer - Siehe Seite 51

Dosensenker Segmente Lasergeschweißt



Type: „KS Star“ 3D Segment (Anschluss M16)

hochverdichteter Kalksandstein
highly compressed sand-lime brick

Ø	Art.-Nr.	Anzahl Segment	Belag Höhe	Preis
68	627003	4	12	51,50 €
82	627004	6	12	59,50 €

mit Absauglöcher im Deckel für Staubabsaugung

68	627013	4	12	51,50 €
82	627014	6	12	59,50 €



Type: „BE90AB“ (Anschluss M16)

Kalksandstein weich, Mauerwerk
soft sand-lime brick, masonry
Länge 90mm, mit mit Absauglöcher im Deckel für Staubabsaugung

Ø	Art.-Nr.	Anzahl Segment	Belag Höhe	Preis
68	627003	3	10	34,70 €
82	627004	4	10	38,40 €

Diamantbohrkronen

Trockenschnitt Softschlag



Stahlbeton Softschlag Nutzlänge 300 mm

Type: K-SLT

Beton bis B55 Armierung bis Ø 32mm, Hartgestein, Mauerwerk
Concrete up to B55 reinforcement up to Ø 32mm, hard stone, masonry

Anschluss: 1 1/4;

Ø	Art.-Nr.	Segment Anzahl	Segment Breite	Belaghöhe 10 mm
32	201500	4	3,4	89,20 €
42	201501	4	3,4	91,28 €
52	201502	5	3,4	105,80 €
62	201503	5	3,4	122,39 €
72	201504	6	3,4	123,77 €
82	201505	6	3,4	136,91 €
92	201506	6	3,4	143,14 €
102	201507	7	3,4	151,44 €
112	201508	7	3,4	153,51 €
122	201509	8	4,0	155,59 €
127	201510	8	4,0	163,88 €
132	201511	8	4,0	174,26 €
142	201512	8	4,0	219,83 €
152	201513	8	4,0	245,35 €
162	201515	9	4,0	258,90 €
182	201516	9	4,0	266,94 €
202	201517	10	4,0	304,23 €

Fliesenbohrer für Winkelschleifer Trockenschnitt



Fliesenbohrer Vacuum Braze „Standard“

Type: K-VBS

Anschluss M14 • Gesamtlänge 60mm • Nutzlänge 40mm
Für Winkelschleifer • Trockenschnitt
Fliesen, Feinsteinzeug, Keramik, Granit, Marmor, GFK •
tiles, hard tile, ceramics, granite, marble

Ø	Art.-Nr.:	Preis
6*	624001	21,90 €
8*	624002	22,30 €
10*	624003	22,70 €
12*	624004	23,60 €
15	624005	24,00 €
16	624006	24,40 €
18	624007	25,60 €
20	624008	28,70 €
22	624009	32,10 €
25	624010	35,40 €
28	624011	40,50 €
30	624012	42,20 €
32	624013	45,60 €
35	624014	50,60 €
40	624015	57,40 €
45	624016	64,10 €
50	624017	70,90 €
55	624018	77,60 €
60	624019	86,10 €
68	624020	92,80 €
80	624021	131,60 €
90	624022	151,90 €
100	624023	161,50 €
110	624024	173,70 €
120	624025	190,80 €

Fliesenbohrer galvanisch

Type: K-FBR

Anschluss Rundschaft • Nutzlänge 35mm • Naßschnitt
Fliesen, Feinsteinzeug, Keramik, Granit, Marmor, Glasfliesen
tiles, hard tile, ceramics, granite, marble



Ø	Art.-Nr.:	Preis
5	623001	11,60 €
6	623002	12,20 €
8	623003	13,80 €
10	623004	15,90 €
12	623005	16,70 €
14	623006	17,90 €
18	623007	20,60 €
20	623008	22,90 €
22	623009	25,30 €
25	623010	29,00 €
32	623011	36,80 €
35	623012	40,30 €
38	623013	44,20 €
40	623014	46,60 €
45	623015	52,00 €
50	623016	58,70 €
60	623017	69,90 €
68	623018	75,30 €
73	623019	85,70 €
75	623020	87,70 €

Vollbohrer ⇒ Nassschnitt



Vollbohrer (Anschluss M12, M14)

Granit, Marmor, Hartgestein, Fliesen, Keramik
granite, marble, hardrock, tiles, ceramics

Ø	Art.-Nr.	Preis
3,5	642001	35,31 €
4	642002	35,31 €
5	642003	35,31 €
6	642004	36,89 €
7	642005	40,03 €
7,5	642006	43,96 €
8	642007	43,96 €
9	642008	46,30 €
10	642009	48,67 €
12	642010	53,37 €
14	642011	59,66 €

Bohrkronenrohlinge



Nutzlänge 450 mm Standard ⇒ (andere Längen lieferbar)
Berechnung bei Überlängen +10% pro 100mm

Div. Anschlüsse 1 1/4" - R1/2" - 3-Loch (andere Anschlüsse lieferbar)

Ø	Art.-Nr.	Wandstärke	Preis
30	210001	1,5 mm	16,20 €
40	210002	1,5 mm	17,30 €
50	210003	2,0 mm	14,90 €
55	210004	2,0 mm	16,80 €
60	210005	2,0 mm	14,90 €
70	210006	2,0 mm	17,10 €
80	210007	2,0 mm	18,40 €
90	210008	2,0 mm	23,50 €
100	210009	2,0 mm	26,30 €
105	210010	2,0 mm	33,50 €
110	210011	2,0 mm	27,10 €
120	210012	2,0 mm	27,90 €
125	210013	2,0 mm	36,60 €
130	210014	2,0 mm	37,30 €
135	210015	2,0 mm	56,60 €
140	210016	2,0 mm	46,10 €
150	210017	2,5 mm	39,40 €
155	210018	2,5 mm	60,90 €
160	210019	2,5 mm	41,30 €
170	210020	2,5 mm	60,30 €
176	210021	2,5 mm	60,30 €
180	210022	2,5 mm	63,60 €
185	210023	2,5 mm	67,50 €
190	210024	2,5 mm	67,50 €
200	210025	2,5 mm	82,20 €

Andere Durchmesser auf Anfrage

Schleif- und Fräswerkzeuge

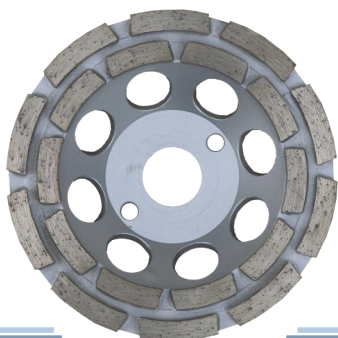

Topfschleifer Standard

Doppelreihig • concrete, abrasive

BetonType: K-TSB

Abrasiv Type: K-TSA

Ø	Art.-Nr.	Bohrung	Preis
125 Abrasiv	630001	22,2	61,50 €
180 Abrasiv	630002	22,2	99,30 €
100 Beton	630003	22,2	47,80 €
115 Beton	630004	22,2	56,90 €
125 Beton	630005	22,2	61,50 €
180 Beton	630006	22,2	99,30 €

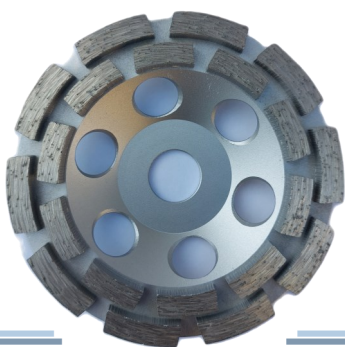

Topfschleifer

Doppelreihig • Beton, Abrasiv • concrete, abrasive

Type: K-SLT

Ø	Art.-Nr.	Bohrung	Preis
100	631001	22,2	19,90 €
115	631002	22,2	23,20 €
125	631003	22,2	25,50 €
150	631004	22,2	44,50 €
180	631008	22,2	57,30 €



Topfschleifer

Beton, Abrasiv • concrete, abrasive

Type: K-TLB

Ø	Art.-Nr.	Bohrung	Preis
125	631010	22,2	28,90 €
150	631011	19	56,60 €
180	631012	22,2	71,50 €



Topfschleifer Premium

Beton, concrete

Type: K-TMB

Ø	Art.-Nr.	Bohrung	Preis
115 Beton	633001	22,2	93,70 €
125 Beton	633002	22,2	101,00 €
150 Beton	633003	19	124,60 €
180 Beton	633004	22,2	134,90 €

Schleif- und Fräswerkzeuge



Topfschleifer PKD

Type: K-TP

Kleberreste, Bitumen, Farbe • glue, bitumen, paint

Ø	Art.-Nr.	Bohrung	Preis
125 Fein	132001	22,2	189,00 €
125 Mittel	132002	22,2	189,00 €
125 Grob	132003	22,2	189,00 €
180 Fein	132004	22,2	229,00 €
180 Mittel	132005	22,2	229,00 €
180 Grob	132006	22,2	229,00 €

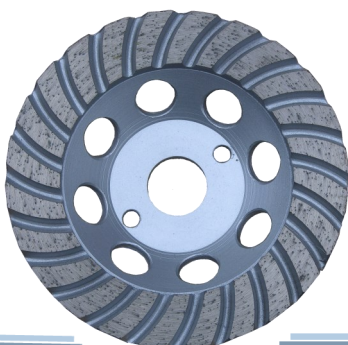

Topfschleifer Premium Turbo

Type: K-TTB

Beton, Granit, Hartstein • concrete, granite, hardrock

Ø	Art.-Nr.	Bohrung	Preis
100	634001	22,2	65,30 €
115	634002	22,2	76,60 €
125	634003	22,2	96,60 €
180	634004	22,2	141,10 €



Schleifteller Turbo Premium

Beton, Granit, Hartstein • concrete, granite, hardrock

Ø	Art.-Nr.	Bohrung	Preis
100	700604	M14	49,90 €
100	700605	22,2	49,90 €
125	700606	22,2	81,20 €
180	700607	22,2	116,00 €

Schleif- und Fräswerkzeuge

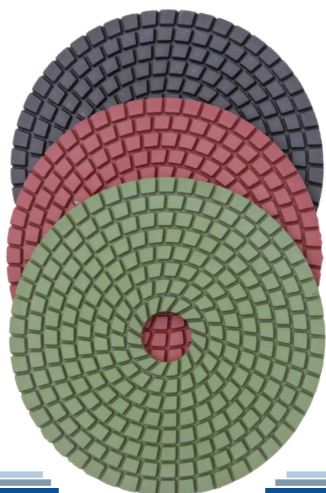

Diamant Polierpads Nassschliff

Type: K-PN

Mit Klettverschluss

Granit, Marmor, Naturstein • granite, marble, natural stone

Ø	Art.-Nr.	Korn	Preis
100	635001	50	13,80 €
100	635002	100	13,80 €
100	635003	200	13,80 €
100	635004	400	13,80 €
100	635005	800	13,80 €
100	635006	1500	13,80 €
100	635007	3000	13,80 €
100	635008	Buff	13,80 €
100 Set	635009	50-Buffer	102,60 €
125	635010	50	22,60 €
125	635011	100	22,60 €
125	635012	200	22,60 €
125	635013	400	22,60 €
125	635014	800	22,60 €
125	635015	1500	22,60 €
125	635016	3000	22,60 €
125	635017	Buff	22,60 €
125 Set	635018	50-Buffer	168,00 €

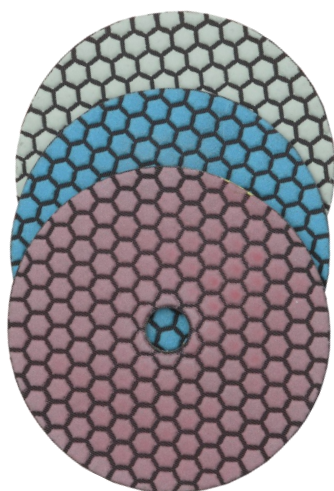

Diamant Polierpads Trockenschliff

Type: K-PT

Mit Klettverschluss

Granit, Marmor, Naturstein • granite, marble, natural stone

Ø	Art.-Nr.	Korn	Preis
100	636001	50	21,90 €
100	636002	100	21,90 €
100	636003	200	21,90 €
100	636004	400	21,90 €
100	636005	800	21,90 €
100	636006	1500	21,90 €
100	636007	3000	21,90 €
100	636008	Buff	21,90 €
100 Set	636009	50-Buffer	156,50 €
125	636010	50	37,30 €
125	636011	100	37,30 €
125	636012	200	37,30 €
125	636013	400	37,30 €
125	636014	800	37,30 €
125	636015	1500	37,30 €
125	636016	3000	37,30 €
125	636017	Buff	37,30 €
125 Set	636018	50-Buffer	257,80 €

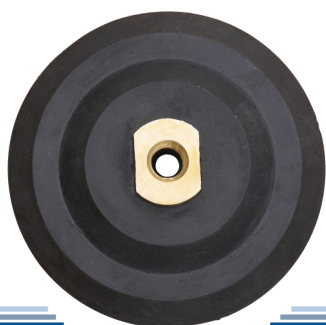

Aufnahmeteller für Polierpads

Mit Klettverschluss

Ø	Art.-Nr.	Anschluss	Preis
100	637001	M14	14,70 €
125	637002	M14	20,10 €

Schleif- und Fräswerkzeuge

Rillenfräser → Beton • concrete			
Segmentlänge = 40mm Belaghöhe 7+1mm			
∅	Art.-Nr.	Segmentbreite mm	Preis
300	134001	5,0	224,10 €
300	134002	6,0	235,00 €
300	134003	7,0	245,80 €
300	134004	8,0	256,70 €
300	134005	9,0	267,60 €
300	134006	10,0	278,50 €
300	134007	12,0	300,30 €
300	134008	15,0	333,00 €
300	134009	20,0	387,50 €
350	134010	5,0	257,20 €
350	134011	6,0	269,90 €
350	134012	7,0	282,60 €
350	134013	8,0	295,30 €
350	134014	9,0	308,00 €
350	134015	10,0	320,70 €
350	134016	12,0	346,20 €
350	134017	15,0	384,30 €
350	134018	20,0	447,90 €
400	134019	5,0	296,60 €
400	134020	6,0	311,20 €
400	134021	7,0	325,70 €
400	134022	8,0	340,20 €
400	134023	9,0	354,70 €
400	134024	10,0	369,30 €
400	134025	12,0	398,30 €
450	134026	5,0	329,30 €
450	134027	6,0	345,00 €
450	134028	7,0	360,70 €
450	134029	8,0	376,50 €
450	134030	9,0	392,20 €
450	134031	10,0	408,00 €
450	134032	12,0	439,40 €
500	134033	5,0	384,00 €
500	134034	6,0	402,10 €
500	134035	7,0	420,30 €
500	134036	8,0	438,50 €
500	134037	9,0	456,60 €
500	134038	10,0	474,80 €
500	134039	12,0	511,10 €
600	134040	5,0	471,30 €
600	134041	6,0	493,10 €
600	134042	7,0	514,90 €
600	134043	8,0	536,70 €
600	134044	9,0	558,50 €
600	134045	10,0	580,30 €
600	134046	12,0	623,90 €



Schleif- und Fräswerkzeuge

Rillenfräser → Asphalt • asphalt Segmentlänge = 40mm Belaghöhe 7+1mm

∅	Art.-Nr.	Segmentbreite mm	Preis
300	135001	5,0	224,80 €
300	135002	6,0	235,80 €
300	135003	7,0	246,80 €
300	135004	8,0	257,90 €
300	135005	9,0	268,90 €
300	135006	10,0	280,00 €
300	135007	12,0	302,00 €
300	135008	15,0	335,20 €
300	135009	20,0	390,40 €
350	135010	5,0	258,00 €
350	135011	6,0	270,90 €
350	135012	7,0	283,80 €
350	135013	8,0	296,70 €
350	135014	9,0	309,50 €
350	135015	10,0	322,40 €
350	135016	12,0	348,20 €
350	135017	15,0	386,80 €
350	135018	20,0	451,20 €
400	135019	5,0	297,60 €
400	135020	6,0	312,30 €
400	135021	7,0	327,00 €
400	135022	8,0	341,70 €
400	135023	9,0	356,50 €
400	135024	10,0	371,20 €
400	135025	12,0	400,30 €
450	135026	5,0	330,30 €
450	135027	6,0	346,20 €
450	135028	7,0	362,20 €
450	135029	8,0	378,10 €
450	135030	9,0	394,10 €
450	135031	10,0	410,00 €
450	135032	12,0	441,90 €
500	135033	5,0	385,20 €
500	135034	6,0	403,60 €
500	135035	7,0	422,00 €
500	135036	8,0	440,40 €
500	135037	9,0	458,80 €
500	135038	10,0	477,20 €
500	135039	12,0	514,00 €
600	135040	5,0	472,70 €
600	135041	6,0	494,80 €
600	135042	7,0	516,90 €
600	135043	8,0	539,00 €
600	135044	9,0	561,10 €
600	135045	10,0	583,10 €
600	135046	12,0	627,30 €



Schleif- und Fräswerkzeuge

Rillenfräser ⇒ *Granit • granite* Segmentlänge = 40mm Belaghöhe 7+1mm

Ø	Art.-Nr.	Segmentbreite mm	Preis
300	136001	5,0	224,10 €
300	136002	6,0	235,00 €
300	136003	7,0	245,80 €
300	136004	8,0	256,70 €
300	136005	9,0	267,60 €
300	136006	10,0	278,50 €
300	136007	12,0	300,30 €
300	136008	15,0	333,00 €
300	136009	20,0	387,50 €
350	136010	5,0	257,20 €
350	136011	6,0	269,90 €
350	136012	7,0	282,60 €
350	136013	8,0	295,30 €
350	136014	9,0	308,00 €
350	136015	10,0	320,70 €
350	136016	12,0	346,20 €
350	136017	15,0	384,30 €
350	136018	20,0	447,90 €
400	136019	5,0	296,60 €
400	136020	6,0	311,20 €
400	136021	7,0	325,70 €
400	136022	8,0	340,20 €
400	136023	9,0	354,70 €
400	136024	10,0	369,30 €
400	136025	12,0	398,30 €
450	136026	5,0	329,30 €
450	136027	6,0	345,00 €
450	136028	7,0	360,70 €
450	136029	8,0	376,50 €
450	136030	9,0	392,20 €
450	136031	10,0	408,00 €
450	136032	12,0	439,40 €
500	136033	5,0	384,00 €
500	136034	6,0	402,10 €
500	136035	7,0	420,30 €
500	136036	8,0	438,50 €
500	136037	9,0	456,60 €
500	136038	10,0	474,80 €
500	136039	12,0	511,10 €
600	136040	5,0	471,30 €
600	136041	6,0	493,10 €
600	136042	7,0	514,90 €
600	136043	8,0	536,70 €
600	136044	9,0	558,50 €
600	136045	10,0	580,30 €
600	136046	12,0	623,90 €



Schleif- und Fräswerkzeuge



Umfangfräser

Granit, Hartgestein • granite, hardrock

Ø	Art.-Nr.	Segment Abmessung	Segment Anzahl	Preis Neu	Preis Wiederbelag
350	13701	40 x 6+4 x 9,0 (schräg)	40	724,30 €	694,20 €
350	13702	30 x 6+4 x 8,0 (gerade)	44	654,90 €	624,90 €
350	13703	24 x 6+4 x 8,0 (gerade)	40	627,20 €	597,20 €
400	13704	40 x 6+4 x 9,0 (schräg)	45	799,40 €	765,80 €
400	13705	30 x 6+4 x 8,0 (gerade)	50	707,70 €	672,70 €
400	13706	24 x 6+4 x 10 (gerade)	45	676,50 €	641,50 €



Fugenfräser

Beton, Mauerwerk • concrete, masonry

⇒ Type: K-F

Ø	Art.-Nr.	Segment Anzahl	Segment Breite mm	Bohrung mm	Belaghöhe 7 mm
115	638001	8	4	22,2	19,00 €
115	638002	8	6	22,2	25,10 €
115	638003	8	8	22,2	29,10 €
125	638004	10	4	22,2	24,30 €
125	638005	10	6	22,2	29,90 €
125	638006	10	8	22,2	34,60 €
125	638007	10	10	22,2	39,90 €
180	638008	14	6	22,2	54,30 €
180	638009	14	10	22,2	64,40 €
230	638010	18	6	22,2	79,90 €
230	638011	18	8	22,2	89,00 €
230	638012	18	10	22,2	99,90 €



Fugenfräser V-Form

Beton, Mauerwerk • concrete, masonry

⇒ Type: K-FV10

Ø	Art.-Nr.	Segment Anzahl	Segment Breite mm	Bohrung mm	Belaghöhe 10 mm
115	639001	8	10	22,2	47,00 €
125	639002	9	10	22,2	53,10 €
180	639003	13	10	22,2	88,90 €
230	639004	16	10	22,2	119,90 €



Fugenfräser 45 Grad

Beton • concrete

⇒ Type: K-FF45

Ø	Art.-Nr.	Segment Anzahl	Segment Breite mm	Bohrung mm	Belaghöhe 10 mm
230	138001	16	7	25,4	307,50 €
300	138002	18	7	25,4	342,70 €
350	138003	21	7	25,4	394,50 €

Schleif- und Fräswerkzeuge

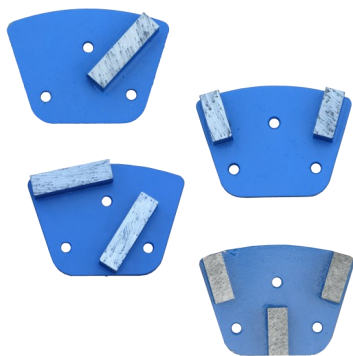

Bodenschleifplatten ⇒ Hartgestein

Granit, Beton, Marmor, Gußasphalt usw.
granite, concrete, marble

Ausführung	Art.-Nr.	Segment Abmessung	Korn	Preis
1 Segment	139001	40 x 10 x 9+3	20/30 - 325/400	26,30 €
2 Segmente	139002	40 x 10 x 9+3	20/30 - 325/400	48,10 €
2 Segmente	139003	24 x 10 x 9+3	20/30 - 325/400	37,60 €
3 Segmente	139004	24 x 10 x 9+3	20/30 - 325/400	54,20 €



Bodenschleifplatten ⇒ abrasive Materialien

Estrich, abrasiver Sandstein, Frischbeton usw.
green concrete, abrasive sandstone, fresh concrete etc.

Ausführung	Art.-Nr.	Segment Abmessung	Korn	Preis
1 Segment	140001	40 x 10 x 9+3	20/30 - 325/400	21,90 €
2 Segmente	140002	40 x 10 x 9+3	20/30 - 325/400	38,90 €
2 Segmente	140003	24 x 10 x 9+3	20/30 - 325/400	32,40 €
3 Segmente	140004	24 x 10 x 9+3	20/30 - 325/400	46,10 €



Bodenschleifplatte PKD

Klebereste, Bitumen, Farbe etc. • glue, bitumen, paint etc.

Ausführung	Art.-Nr.	Preis
Grob	141001	99,00 €
Mittel	141002	99,00 €
Fein	141003	99,00 €

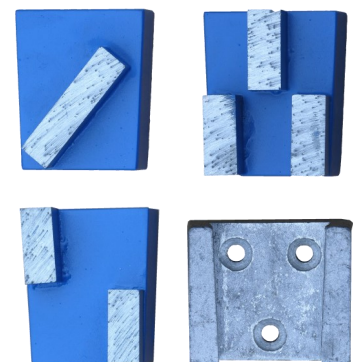

Schnellwechselsystem für Bodenschleifmaschinen

Abrasiv Materialien, Hartgestein • abrasive materials, hardrock

Ausführung	Art.-Nr.	Segment Abmessung	Korn	Preis
Hartgestein 1	142001	40 x 10 x 9+3	20/30 - 325/400	31,30 €
Abrasiv 1	142002	40 x 10 x 9+3	20/30 - 325/400	26,90 €
Hartgestein 2	142003	24 x 10 x 9+3	20/30 - 325/400	42,60 €
Abrasiv 2	142004	24 x 10 x 9+3	20/30 - 325/400	37,40 €
Hartgestein 3	142005	24 x 10 x 9+3	20/30 - 325/400	59,20 €
Abrasiv 3	142006	24 x 10 x 9+3	20/30 - 325/400	51,10 €
Werkzeugaufnahme	142007	24 x 10 x 9+3	20/30 - 325/400	20,90 €

Schleif- und Fräswerkzeuge

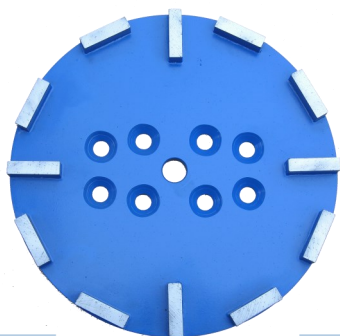

Bodenschleifteller ⇒ Hartgestein

Granit, Beton, Marmor, Gußasphalt usw. •
granite, concrete, marble etc.

Ø	Art.-Nr.	Segment Anzahl	Segment Abmessung	Korn	Preis
250	143001	12	40 x 10 x 9+3	20/30 - 325/400	299,90 €
300	143002	16	40 x 10 x 9+3	20/30 - 325/400	371,30 €

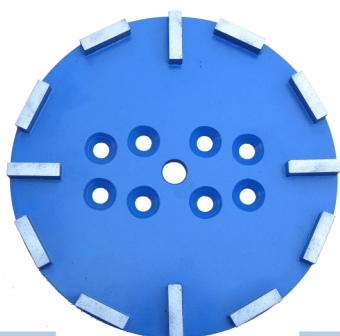

Bodenschleifteller ⇒ abrasive Materialien

Estrich, abrasiver Sandstein, Frischbeton usw. •
green concrete, abrasive sandstone, fresh concrete

Ø	Art.-Nr.	Segment Anzahl	Segment Abmessung	Korn	Preis
250	144001	12	40 x 10 x 9+3	20/30 - 325/400	299,90 €
300	144002	16	40 x 10 x 9+3	20/30 - 325/400	371,30 €

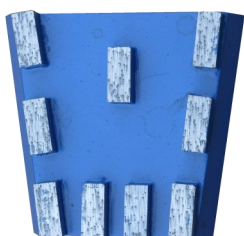

Schleifschuhe „Form Frankfurt“

Granit, Marmor, Hartgestein • granite, marble, hardrock

Segment Abmessung	Art.-Nr.	Segment Anzahl	Preis
24 x 10 x 9+3	145001	9	133,60 €
24 x 7 x 9+3	145002	11	133,60 €

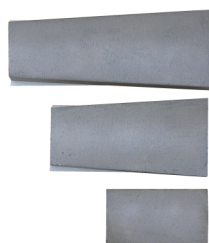

Diamant-Schleifleisten (Wackelkopf)

Granit, Marmor, Hartgestein • granite, marble, hardrock

Abmessung	Art.-Nr.	Preis (incl. Aufnahme)
90 x 50 x 12+3	146001	135,50 €
140 x 60 x 12+3	146002	179,60 €
180 x 60 x 12+3	146003	222,90 €

Segmente für Bohrkronen ⇒ Belaghöhe 7mm

Type: GZ

Granit, Hartstein • granite, hardrock



Durchmesser 14 - 35mm

Maße in mm	Ø	Art.-Nr.	Preis
10 x 3,0 x 7	14	301011	3,11 €
12 x 3,0 x 7	16	301012	3,23 €
13 x 3,0 x 7	18	301013	3,29 €
15 x 3,0 x 7	20	301014	3,41 €
16 x 3,0 x 7	22	301015	3,47 €
18 x 3,0 x 7	25	301016	3,58 €
22 x 3,0 x 7	30	301017	3,82 €
26 x 3,0 x 7	35	301018	4,05 €

Durchmesserbereiche bei Bestellung bitte angeben!

Ø 14-80mm exakten Durchmesser
angeben

Ø 100mm (verwendbar für Ø 90-110)

Ø 120mm (verwendbar für Ø 100-150)

Ø 170mm (verwendbar für Ø 150-200)

Ø 250mm (verwendbar für Ø 200-350)

Durchmesser 40 - 350mm

Maße in mm	Art.-Nr.	Preis
24 x 3,0 x 7	302011	3,93 €
24 x 3,5 x 7	302012	4,17 €
24 x 4,0 x 7	302013	4,40 €
24 x 4,5 x 7	302014	4,63 €
24 x 5,0 x 7	302015	4,87 €
24 x 5,5 x 7	302016	5,10 €
24 x 6,0 x 7	302017	5,33 €



Durchmesser > 350mm

Maße in mm	Art.-Nr.	Preis
20 x 4,6 x 7	303011	4,32 €
20 x 5,0 x 7	303012	4,48 €
20 x 5,5 x 7	303013	4,67 €
20 x 6,0 x 7	303014	4,87 €

Segmente für Bohrkronen ⇒ Belaghöhe 7mm

Type: MB

Marmor, Fliesen, Weichgestein • marble, tiles, softstone



Durchmesser 14 - 35mm

Maße in mm	Ø	Art.-Nr.	Preis
10 x 3,0 x 7	14	304011	3,11 €
12 x 3,0 x 7	16	304012	3,23 €
13 x 3,0 x 7	18	304013	3,29 €
15 x 3,0 x 7	20	304014	3,41 €
16 x 3,0 x 7	22	304015	3,47 €
18 x 3,0 x 7	25	304016	3,58 €
22 x 3,0 x 7	30	304017	3,82 €
26 x 3,0 x 7	35	304018	4,05 €

Durchmesserbereiche bei Bestellung bitte angeben!

Ø 14-80mm exakten Durchmesser
angeben

Ø 100mm (verwendbar für Ø 90-110)

Ø 120mm (verwendbar für Ø 100-150)

Ø 170mm (verwendbar für Ø 150-200)

Ø 250mm (verwendbar für Ø 200-350)

Durchmesser 40 - 350mm

Maße in mm	Art.-Nr.	Preis
24 x 3,0 x 7	305011	3,93 €
24 x 3,5 x 7	305012	4,17 €
24 x 4,0 x 7	305013	4,40 €
24 x 4,5 x 7	305014	4,63 €
24 x 5,0 x 7	305015	4,87 €
24 x 5,5 x 7	305016	5,10 €
24 x 6,0 x 7	305017	5,33 €



Durchmesser > 350mm

Maße in mm	Art.-Nr.	Preis
20 x 4,6 x 7	306011	4,32 €
20 x 5,0 x 7	306012	4,48 €
20 x 5,5 x 7	306013	4,67 €
20 x 6,0 x 7	306014	4,87 €

Segmente für Bohrkronen Belaghöhe 7mm

Type: GK

Beton, Stahlbeton, Mauerwerk • concrete, reinforced concrete, masonry ⇒ K30/K40

Asphalt, Frischbeton, abrasive Materialien • asphalt, fresh concrete, abrasive ⇒ K40/K60



Durchmesser 14 - 35mm

Maße in mm	Ø	Art.-Nr.	K30	Art.-Nr.	K40	Art.-Nr.	K60
10 x 3,0 x 7	14	307011	3,36 €	307012	3,63 €	307013	3,98 €
12 x 3,0 x 7	16	307021	3,49 €	307022	3,79 €	307023	4,17 €
13 x 3,0 x 7	18	307031	3,56 €	307032	3,86 €	307033	4,26 €
15 x 3,0 x 7	20	307041	3,69 €	307042	4,02 €	307043	4,45 €
16 x 3,0 x 7	22	307051	3,76 €	307052	4,09 €	307053	4,54 €
18 x 3,0 x 7	25	307061	3,89 €	307062	4,24 €	307063	4,73 €
22 x 3,0 x 7	30	307071	4,16 €	307072	4,55 €	307073	5,11 €
26 x 3,0 x 7	35	307081	4,42 €	307082	4,86 €	307083	5,48 €

Durchmesserbereiche bei Bestellung bitte angeben!

Ø 14-80mm exakten Durchmesser angeben

Ø 100mm (verwendbar für Ø 90-110)

Ø 120mm (verwendbar für Ø 100-150)

Ø 170mm (verwendbar für Ø 150-200)

Ø 250mm (verwendbar für Ø 200-350)

Durchmesser 40 - 350mm

Maße in mm	Art.-Nr.	K30	Art.-Nr.	K40	Art.-Nr.	K60
24 x 3,0 x 7	308011	4,29 €	308012	4,70 €	308013	5,29 €
24 x 3,5 x 7	308021	4,55 €	308022	5,01 €	308023	5,67 €
24 x 4,0 x 7	308031	4,82 €	308032	5,32 €	308033	6,05 €
24 x 4,5 x 7	308041	5,08 €	308042	5,62 €	308043	6,42 €
24 x 5,0 x 7	308051	5,35 €	308052	5,93 €	308053	6,80 €
24 x 5,5 x 7	308061	5,61 €	308062	6,23 €	308063	7,17 €
24 x 6,0 x 7	308071	5,88 €	308072	6,54 €	308073	7,55 €



Durchmesser > 350mm

Maße in mm	Art.-Nr.	K30	Art.-Nr.	K40	Art.-Nr.	K60
20 x 4,6 x 7	309011	4,73 €	309012	5,21 €	309013	5,92 €
20 x 5,0 x 7	309021	4,91 €	309022	5,42 €	309023	6,17 €
20 x 5,5 x 7	309031	5,13 €	309032	5,67 €	309033	6,48 €
20 x 6,0 x 7	309041	5,35 €	309042	5,93 €	309043	6,80 €

Segmente für Bohrkronen Belaghöhe 10mm

Type: GK

Beton, Stahlbeton, Mauerwerk • concrete, reinforced concrete, masonry

Durchmesserbereiche bei Bestellung bitte angeben!

- Ø 40-80mm exakten Durchmesser angeben
- Ø 100mm (verwendbar für Ø 90-110)
- Ø 120mm (verwendbar für Ø 100-150)
- Ø 170mm (verwendbar für Ø 150-200)
- Ø 250mm (verwendbar für Ø 200-350)



Durchmesser 40 - 350mm

Maße in mm	Art.-Nr.	K30	Art.-Nr.	K40
24 x 3,0 x 10	310011	5,51 €	310012	5,89 €
24 x 3,5 x 10	310021	5,89 €	310022	6,31 €
24 x 4,0 x 10	310031	6,26 €	310032	6,73 €
24 x 4,5 x 10	310041	6,64 €	310042	7,16 €
24 x 5,0 x 10	310051	7,02 €	310052	7,58 €
24 x 5,5 x 10	310061	7,40 €	310062	8,01 €
24 x 6,0 x 10	310071	7,78 €	310072	8,43 €

Durchmesser > 350 mm (gerade Segmente)

Maße in mm	Art.-Nr.	K30	Art.-Nr.	K40
20 x 4,6 x 10	311011	6,14 €	311012	6,59 €
20 x 5,0 x 10	311021	6,39 €	311022	6,87 €
20 x 5,5 x 10	311031	6,71 €	311032	7,23 €
20 x 6,0 x 10	311041	7,02 €	311042	7,58 €

Segmente für Bohrkronen Belaghöhe 7mm

Type: B2
Schnittfreudig

Beton, Stahlbeton • concrete, reinforced concrete

Durchmesserbereiche bei Bestellung bitte angeben!

- Ø 40-80mm exakten Durchmesser angeben
- Ø 100mm (verwendbar für Ø 90-110)
- Ø 120mm (verwendbar für Ø 100-150)
- Ø 170mm (verwendbar für Ø 150-200)
- Ø 250mm (verwendbar für Ø 200-350)



Durchmesser 40-350 mm

Maße in mm	Art.-Nr.	Preis
24 x 3,0 x 7	312001	4,09 €
24 x 3,5 x 7	312002	4,32 €
24 x 4,0 x 7	312003	4,55 €
24 x 4,5 x 7	312004	4,78 €
24 x 5,0 x 7	312005	5,01 €
24 x 5,5 x 7	312006	5,24 €
24 x 6,0 x 7	312007	5,47 €

Durchmesser > 350 mm (gerade Segmente)

Maße in mm	Art.-Nr.	Preis
20 x 4,6 x 7	313001	4,47 €
20 x 5,0 x 7	313002	4,63 €
20 x 5,5 x 7	313003	4,82 €
20 x 6,0 x 7	313004	5,01 €

Segmente für Bohrkronen Belaghöhe 10mm

Beton, Stahlbeton • concrete, reinforced concrete

Type: **BF78**

Schnellschnitt

Durchmesserbereiche bei Bestellung bitte angeben!

- Ø 40-80mm exakten Durchmesser angeben
- Ø 100mm (verwendbar für Ø 90-110)
- Ø 120mm (verwendbar für Ø 100-150)
- Ø 170mm (verwendbar für Ø 150-200)
- Ø 250mm (verwendbar für Ø 200-350)



Durchmesser 40-350 mm

Maße in mm	Art.-Nr.	Preis
24 x 3,0 x 10	314001	4,80 €
24 x 3,5 x 10	314002	5,09 €
24 x 4,0 x 10	314003	5,38 €
24 x 4,5 x 10	314004	5,67 €
24 x 5,0 x 10	314005	5,97 €
24 x 5,5 x 10	314006	6,26 €
24 x 6,0 x 10	314007	6,55 €

Durchmesser > 350 mm (gerade Segmente)

Maße in mm	Art.-Nr.	Preis
20 x 4,6 x 10	315001	5,28 €
20 x 5,0 x 10	315002	5,48 €
20 x 5,5 x 10	315003	5,72 €
20 x 6,0 x 10	315004	5,97 €

Dachsegmente für Bohrkronen Belaghöhe 8,5mm

Beton, Stahlbeton • concrete, reinforced concrete

Type: **BF78D**

Schnellschnitt

Durchmesserbereiche bei Bestellung bitte angeben!

- Ø 40-80mm exakten Durchmesser angeben
- Ø 100mm (verwendbar für Ø 90-110)
- Ø 120mm (verwendbar für Ø 100-150)
- Ø 170mm (verwendbar für Ø 150-200)
- Ø 250mm (verwendbar für Ø 200-350)



Durchmesser 40-350 mm

Maße in mm	Art.-Nr.	Preis
24 x 3,0 x 8,5	316001	4,53 €
24 x 3,5 x 8,5	316002	4,78 €
24 x 4,0 x 8,5	316003	5,03 €
24 x 4,5 x 8,5	316004	5,28 €
24 x 5,0 x 8,5	316005	5,53 €
24 x 5,5 x 8,5	316006	5,78 €
24 x 6,0 x 8,5	316007	6,03 €

Ringsegmente für Diamantbohrkronen ringsegments



Ringsegmente für Beton, Stahlbeton

concrete, reinforced concrete

Ø	Art.-Nr.	Segment Breite	Preis
10	322001	2,5	22,10 €
12	322002	2,5	22,90 €
14	322003	2,5	23,20 €
16	322004	2,5	23,40 €
17	322005	2,5	23,60 €
18	322006	2,5	23,70 €
20	322007	2,5	25,20 €
22	322008	2,5	25,40 €
24	322009	2,5	25,60 €
25	322010	2,5	26,70 €
28	322011	2,5	27,30 €
30	322012	2,5	28,20 €
32	322013	2,5	28,40 €
35	322014	3,0	35,70 €
40	322015	3,0	41,80 €



Ringsegmente für Granit, Hartgestein

Granite, hardrock

Ø	Art.-Nr.	Segment Breite	Preis
10	323001	2,5	22,10 €
12	323002	2,5	22,90 €
14	323003	2,5	23,20 €
16	323004	2,5	23,40 €
17	323005	2,5	23,60 €
18	323006	2,5	23,70 €
20	323007	2,5	25,20 €
22	323008	2,5	25,40 €
24	323009	2,5	25,60 €
25	323010	2,5	26,70 €
28	323011	2,5	27,30 €
30	323012	2,5	28,20 €
32	323013	2,5	28,40 €
35	323014	3,0	35,70 €
40	323015	3,0	41,80 €



Ringsegmente für abrasive Materialien

abrasive materials

Ø	Art.-Nr.	Segment Breite	Preis
10	324001	2,5	23,20 €
12	324002	2,5	24,00 €
14	324003	2,5	24,30 €
16	324004	2,5	24,60 €
17	324005	2,5	24,90 €
18	324006	2,5	25,10 €
20	324007	2,5	26,40 €
22	324008	2,5	26,70 €
24	324009	2,5	28,00 €
25	324010	2,5	28,60 €
28	324011	2,5	29,00 €
30	324012	2,5	29,60 €
32	324013	2,5	29,80 €
35	324014	3,0	37,40 €
40	324015	3,0	43,90 €

Abzug Wiederbelag Diamantscheiben

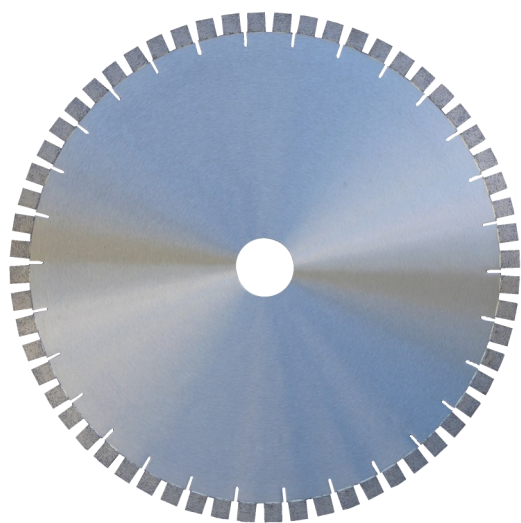

Abzug Wiederbelag vom Nettopreis

Ø	Preis
250	3,70 €
275	3,70 €
300	3,80 €
350	5,00 €
380	6,90 €
400	6,90 €
450	11,10 €
500	11,50 €
550	21,70 €
600	18,00 €
625	21,10 €
650	26,10 €
700	26,10 €
725	26,10 €
750	31,60 €
800	34,00 €
825	34,00 €
850	39,40 €
900	44,90 €
1000	59,40 €
1100	86,40 €
1200	106,20 €
1300	211,80 €
1400	229,40 €
1500	257,40 €
1600	376,80 €
1800	659,50 €
2000	709,50 €

Berechnungsbeispiel:	
Granit Normal- oder Leisekern	246,30 €
Granit Ø 500 15mm Belag	
Abzug Rabatt 10%	24,63 €
Nettopreis	221,67 €
Abzug Wiederbelag	11,50 €
Rechnungsbetrag zzgl. MwSt.	210,17 €

Adapter und Verlängerungen

adapter and extension



Adapter, Verlängerungen etc.

Artikelbezeichnung	Art.-Nr.	Preis
Verlängerung 1 1/4 NL100mm Stahl	401001	19,50 €
Verlängerung 1 1/4 NL200mm Stahl	401002	23,80 €
Verlängerung 1 1/4 NL300mm Stahl	401003	30,60 €
Verlängerung 1 1/4 NL400mm Stahl	401004	41,00 €
Verlängerung 1 1/4 NL500mm Stahl	401005	46,30 €
Verlängerung 1 1/4 NL1000mm Stahl	401006	121,50 €
Verlängerung 1 1/4 NL100mm Alu	401007	32,60 €
Verlängerung 1 1/4 NL200mm Alu	401008	47,00 €
Verlängerung 1 1/4 NL300mm Alu	401009	63,30 €
Verlängerung 1 1/4 NL400mm Alu	401010	66,80 €
Verlängerung 1 1/4 NL500mm Alu	401011	72,00 €
Verlängerung R1/2 NL100mm Stahl	401012	16,80 €
Verlängerung R1/2 NL200mm Stahl	401013	21,70 €
Verlängerung R1/2 NL300mm Stahl	401014	29,30 €
Verlängerung R1/2 NL400mm Stahl	401015	35,10 €
Verlängerung R1/2 NL500mm Stahl	401016	44,30 €
Adapter 1 1/4 Muffe - R1/2 Muffe	401017	18,30 €
Adapter 1 1/4 Muffe - BBT Zapfen	401018	23,10 €
Adapter 1 1/4 Muffe - Würth Zapfen	401019	58,30 €
Adapter 1 1/4 Muffe - M38 Zapfen	401020	23,10 €
Adapter 1 1/4 Muffe - M30 Zapfen	401021	29,20 €
Adapter 1 1/4 Muffe - M16 Zapfen	401022	38,50 €
Adapter 1 1/4 Zapfen - R1/2 Zapfen	401023	18,40 €
Adapter 1 1/4 Zapfen - BBT Muffe	401024	23,20 €
Adapter 1 1/4 Zapfen - Würth Muffe	401025	58,30 €
Adapter 1 1/4 Zapfen - M38 Muffe	401026	23,20 €
Adapter BBT Muffe - R1/2 Muffe	401027	23,20 €
Adapter BBT Zapfen - R1/2 Zapfen	401028	23,20 €
Adapter BBT Zapfen - M38 Muffe	401029	68,90 €
Adapter M16 Zapfen - R1/2 Muffe	401030	16,90 €
Adapter M16 Zapfen - R1/2 Zapfen	401031	16,90 €
Adapter R1/2 Muffe - 6-Kant	401032	28,40 €
Adapter R1/2 Zapfen - M30 Zapfen	401033	29,20 €
Adapter SDT - M16 Zapfen	401034	9,90 €
Adapter 6-Kant - M16 Zapfen	401035	5,80 €
Adapter 3-Loch - 1 1/4 Muffe	401036	16,80 €
Adapter für Schleifteller 22,2 - M14	401037	7,20 €

Andere Adapter bzw. Verlängerungen auf Anfrage



402001



402002



402003



402004



402005



402019

Zubehör

Artikelbezeichnung	Art.-Nr.	Preis
Anbohrhilfe Edelstahl klein	402001	42,50 €
Anbohrhilfe kugelgelagert Premium	402002	87,90 €
Anbohrhilfe Kunststoff groß	402003	19,60 €
Anbohrhilfe Kunststoff klein	402004	16,50 €
Wasserdruckbehälter 10 Liter Metall	402005	209,00 €
Staubabsaugung M16 Muffe - 1 1/4 Zapfen	402006	118,90 €
Wasserspülbüchse M16 - R 1/2	402007	85,90 €
Wasserspülbüchse 6-Kant - R 1/2	402008	73,70 €
Adapter SDS - M16 Zapfen	401034	9,90 €
Adapter 6-Kant - M16 Zapfen	401035	5,80 €
Zentrierbohrer	401038	3,70 €
Staubabsaugung M16 Muffe - M16 Zapfen	402012	54,90 €
Staubabsaugung 5/8" Muffe - M16 Zapfen	402013	54,90 €
Kordelgewindestange M12	402014	12,90 €
Tellerflügelmutter	402015	6,90 €
Schlaganker M12	402016	0,59 €
Schlaganker M12 Paket 50 Stück	402017	24,90 €
Mauerbefestigungsset	402018	23,50 €
Kupferringe	402019	0,95 €
Schlageisen für Schlaganker M12	402020	10,90 €
Staubabsaugung für Winkelschleifer Ø 125	402021	97,80 €
Staubabsaugung für Winkelschleifer Ø 230	402022	155,90 €

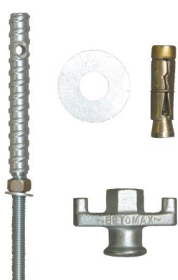

402018



402014

402015

402016



402012



402006



402007



402008



402021



401035



401038



401034

Maschinen

- **Steintrennsägen**
- **Kernbohrstative**
- **Kernbohrmotoren**
- **Bodenschleifmaschinen**
- **Handmaschinen**



Maschinen für unterschiedlichste Anwendungsgebiete auf Anfrage lieferbar.

Bestellkarte *per Fax an (02721) 79313*

Ihre Daten:

Firma:

Strasse:

PLZ/Ort:

Tel.:-Nr.:

Scheiben/Schleifteller

Stück	Anwendung	Ø	Bohrung	Belaghöhe	Verz. N	Verz. Eng	Type	Art.-Nr.

Bohrkronen

Stück	Anwendung	Ø	Anschluss	Belaghöhe	Nutzlänge	Type	Art.-Nr.

Segmente

Stück	Anwendung	Abmessung	Konz.	Korn	Type	Ø	Art.-Nr.

Datum:

Stempel :

Unterschrift:

